

# AmphiBlast™ Lite

## OPERATION AND MAINTENANCE MANUAL

July 2019

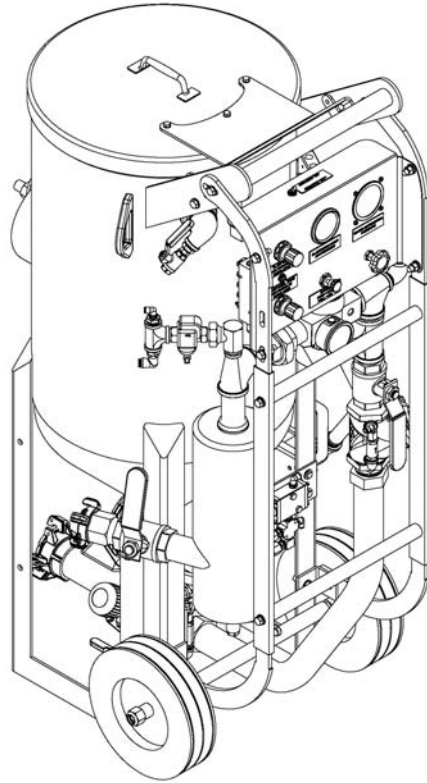

# SCHMIDT®

SAVE THIS MANUAL AND MAKE AVAILABLE  
TO ALL USERS OF THIS EQUIPMENT!

Manual Part Number 7200-350 rev 10-19  
(Available for downloading from [SchmidtAbrasiveBlasting.com](http://SchmidtAbrasiveBlasting.com))



Website



Manual

Copyright © 2019 AXXIOM Manufacturing, Inc.  
11927 S. Highway 6, Fresno, Texas 77545  
800.231.2085 \* 281.431.0581 \* fax 281.431.1717  
Visit us at [www.SchmidtAbrasiveBlasting.com](http://www.SchmidtAbrasiveBlasting.com)

# WARNING

- 1. Any person intending to operate this equipment or any person intending to be in the vicinity during its operation must receive proper training from his/her supervisor, employer and/or supplier. If this equipment is to be leased or rented, the supplier must assure that the lessee or renter has received proper training before the lessee or renter takes possession of the equipment. Consult Axxiom Manufacturing, Inc.**
- 2. Any person authorized to operate this equipment or any person intending to be in the vicinity during its operation and who is not capable of reading and understanding this manual must be fully trained regarding the *Rules for Safer Operation* and all operating procedures, and must be made aware of all the Dangers, Warnings, and Cautions identified herein. Consult Axxiom Manufacturing, Inc.**
- 3. Do Not operate any abrasive blaster or blast equipment before reading and completely understanding all the warnings, operating procedures and instructions, and the *Rules for Safer Operation* contained in this manual.**
- 4. Do Not operate any abrasive blaster or blast equipment without following the *Rules for Safer Operation* and all the operating procedures and instructions. Failure to properly use blast equipment could result in serious injury or death.**
- 5. Do Not perform any maintenance on any abrasive blaster or blast equipment while it is pressurized. Always depressurize the abrasive blaster vessel before loading abrasive or performing any maintenance.**
- 6. Do Not use abrasives containing free silica. Silica can cause silicosis or other related respiratory damage. All operators must wear personal protective equipment for all abrasive blasting operations. Observe all applicable local, state and federal safety regulations in conjunction with airline filters and respiratory protection. Reference OSHA 29 CFR 1910.134.**
- 7. Do Not enter areas during abrasive blasting operations without breathing protection. All personnel in the vicinity of abrasive blasting operations should wear NIOSH approved air fed respirators, hoods or helmets.**
- 8. Do Not modify or alter any abrasive blaster, blast equipment or controls thereof without written consent from Axxiom Manufacturing, Inc.**
- 9. Do Not use bleeder type deadman valves on any Schmidt® abrasive blaster. The use of A-BEC, Clemco or a similar bleeder type deadman valve can cause unintentional start-up without warning, which can result in serious personal injury.**
- 10. Do Not sell, rent, or operate abrasive blasters without remote controls. OSHA regulations require remote controls on all blast machines. Failure to use remote controls can cause serious injury or death to the operator(s) or other personnel in the blasting area. Reference OSHA 29 CFR 1910.244(b).**
- 11. Do Not repair or replace any portion of Schmidt® equipment using components that are not Schmidt® original factory replacement parts. Use of replacement components that are not Schmidt® original factory replacement parts may result in equipment failure which can result in serious personal injury and in addition will void all warranties.**

## Manual Use, Explanation of Safety Symbols, and Glossary

This manual contains information needed to operate and maintain a Schmidt® AmphiBlast™. Read this entire operations and maintenance manual before using the AmphiBlast. Pay close attention to the *Rules for Safer Operation* (Section 1.0), and the Dangers, Warnings, and Cautions identified.

The purpose of safety symbols and explanations are to alert operators of the possible hazards and explain how to avoid them. The safety symbols and explanations alone do not eliminate any danger. However, following the instructions given and taking proper accident prevention measures will greatly lower the risk of injury to personnel. Below are the three hazard levels as used in this manual.

### **DANGER**

**WHITE LETTERS with RED BACKGROUND**

**DANGER:** Indicates an imminently hazardous situation that, if not avoided, will result in death or serious injury. This signal word is limited to the most extreme situations.

### **WARNING**

**BLACK LETTERS with ORANGE BACKGROUND**

**WARNING:** Indicates a potentially hazardous situation that, if not avoided, could result in death or serious injury.

### **CAUTION**

**BLACK LETTERS with YELLOW BACKGROUND**

**CAUTION:** Indicates a potentially hazardous situation that, if not avoided, may result in minor or moderate injury. It may also be used to alert against unsafe practices that may cause property damage.

### **NOTICE**

**WHITE LETTERS with BLUE BACKGROUND**

**NOTICE:** Indicates that equipment could potentially become damaged if certain instructions are not followed.

This manual contains terms that may be specific to the abrasive blast industry. Understanding these terms will help operators understand the procedures and instructions given in this manual. All operators must be familiar with the following terms and refer to them as needed while reading this manual.

Term	Definition
Pressure Vessel	A fabricated tank (or reservoir) that is part of the abrasive blaster which is filled with compressed air and abrasive. (Also referred to as “blast vessel” or “vessel”.)
Pressurize	To manually or automatically fill the abrasive blast vessel with compressed air.
Depressurize	To manually or automatically release all the compressed air from inside the abrasive blast vessel. (Also referred to as “blowdown”.)
Depressurized System	An abrasive blaster that is pressurized only when the deadman activates the blast operation. The blaster automatically depressurizes when the deadman is released.
Pressurized System	An abrasive blaster that is automatically pressurized when the air inlet ball valve is opened. The blaster remains pressurized when the deadman is released.
Blowdown	To manually or automatically release all the compressed air from inside the abrasive blast vessel. (Also referred to as “depressurize”.)
Deadman	A manually operated valve or switch that allows remote starting and stopping of the blast operation. [Also referred to as “deadman valve” (pneumatic blast controls) or “deadman switch” (electric blast controls).]
Popup	An air pressure operated valve that seals the abrasive inlet at the top of the pressure vessel. Its operation may be manual or automatic.
Abrasive	A granular substance used in an air blast operation that is the means for blasting the surface of an object. (Also referred to as abrasive blasting media.)
Silica	The crystalline chemical compound silicon dioxide (SiO <sub>2</sub> ) which can be found in many natural abrasives and other substances. Breathing silica dust can cause respiratory diseases such as silicosis. (Also referred to as crystalline silica)

## 0.0 Warning Decal Identification and Location

Listed below are the warning decals and the corresponding hazards related to this equipment. Refer to Figure 0.1(a) thru 0.1(c) for images of the warning decals. Refer to Figures 0.2(a) and 0.2(b) for the locations of these warning decals on the abrasive blaster.

No.	Qty.	Part no.	Description	Hazard
1.	1	7031-002	Small "Schmidt"	Not Applicable
2.	-	-	-	-
3.	1	7031-054	"Warning" Airborne particle and loud noise hazard.	Airborne particles and loud noise from blast nozzle and blowdown can cause injury and loss of hearing. Wear approved eye and ear protection. See Section 1.0 and 3.10.
4.	1	7031-007B	"Danger" Pressurized vessel.	Propelled objects will cause serious injury or death. Depressurize vessel prior to performing any maintenance. See Section 6.2.
5.	1	7031-057	"Warning" Read manual before using this machine.	Read and understand operator's manual before using this machine. Failure to follow operating instructions could result in injury or damage to equipment. See Section 1.0.
6.	1	7031-077	"Warning" Pinch point hazard.	Vessel pressurization will close popup. Closing popup can pinch and crush. Keep hands and fingers away from popup.
7.	1	7031-082	"Danger" Pressurized vessel Handway components	Propelled objects will cause serious injury or death. Incorrect or damaged handway or manway cover components can result in failure. See Section 6.4.
8.	1	7031-084	"Warning" plate decal. General hazard and advisory notes.	"Warning" decal applied to pressure vessel which is a general list of required actions to take before and during the operation of this equipment. See Section 1.0.
9.	1	7031-017	"Inlet"	Not Applicable
10.	2	7031-087	"USPAT"	Not Applicable
11.	-	-	-	-
12.	1	7031-089	Small "AmphiBlast"	Not Applicable
13.	1	7031-090	"Notice" Threaded coupling.	Replacing the full port threaded coupling on the injection module with another type will result in equipment malfunction. Use the correct part or the adapter hose provided with the equipment.
14.	1	7031-094	Amphiblast™ Lite Mode Settings	Not Applicable



1) 7031-002 (4-5/16" x 4-1/2")



3) 7031-054

**Figure 0.1(a) – Warning Decal Summary**



4) 7031-007B



5) 7031-057



6) 7031-077



7) 7031-082

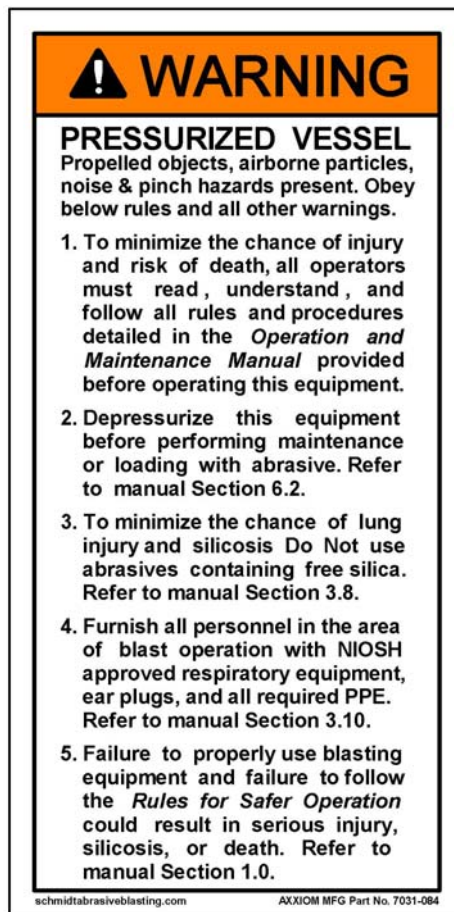

8) 7031-084 (decal)

Figure 0.1(b) – Warning Decal Summary (continued)

**INLET**

USPAT WWW.SCHMIDTPATENTS.COM

9) 7031-017

10) 7031-087



12) 7031-089 (3" x 11")

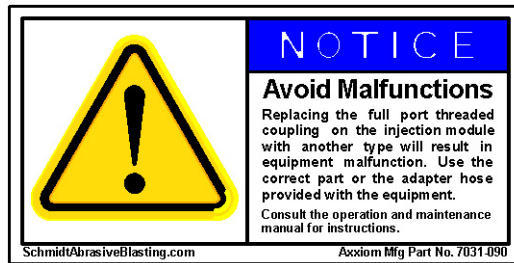

13) 7031-090

AmphiBlast Modes	Panel Setting		
	A (air pressure)	B (water)	C (abrasive)
<b>Wet Blast</b> (High Pressure Air, Water & Abrasive)	↑ HIGH	← ON	↑ ON
<b>Dry Blast</b> (High Pressure Air & Abrasive)	↑ HIGH	→ OFF	↑ ON
<b>Softwash™</b> (Low Pressure Air & Water)	↓ LOW	← ON	↓ OFF
<b>Blowoff Low</b> (Low Pressure Air Only)	↓ LOW	→ OFF	↓ OFF
<b>Blowoff High</b> (High Pressure Air Only)	↑ HIGH	→ OFF	↓ OFF

SchmidtAbrasiveBlasting.com Axxiom Mfg Part No. 7031-094

14) 7031-094

Figure 0.1(c) – Warning Decal Summary (continued)

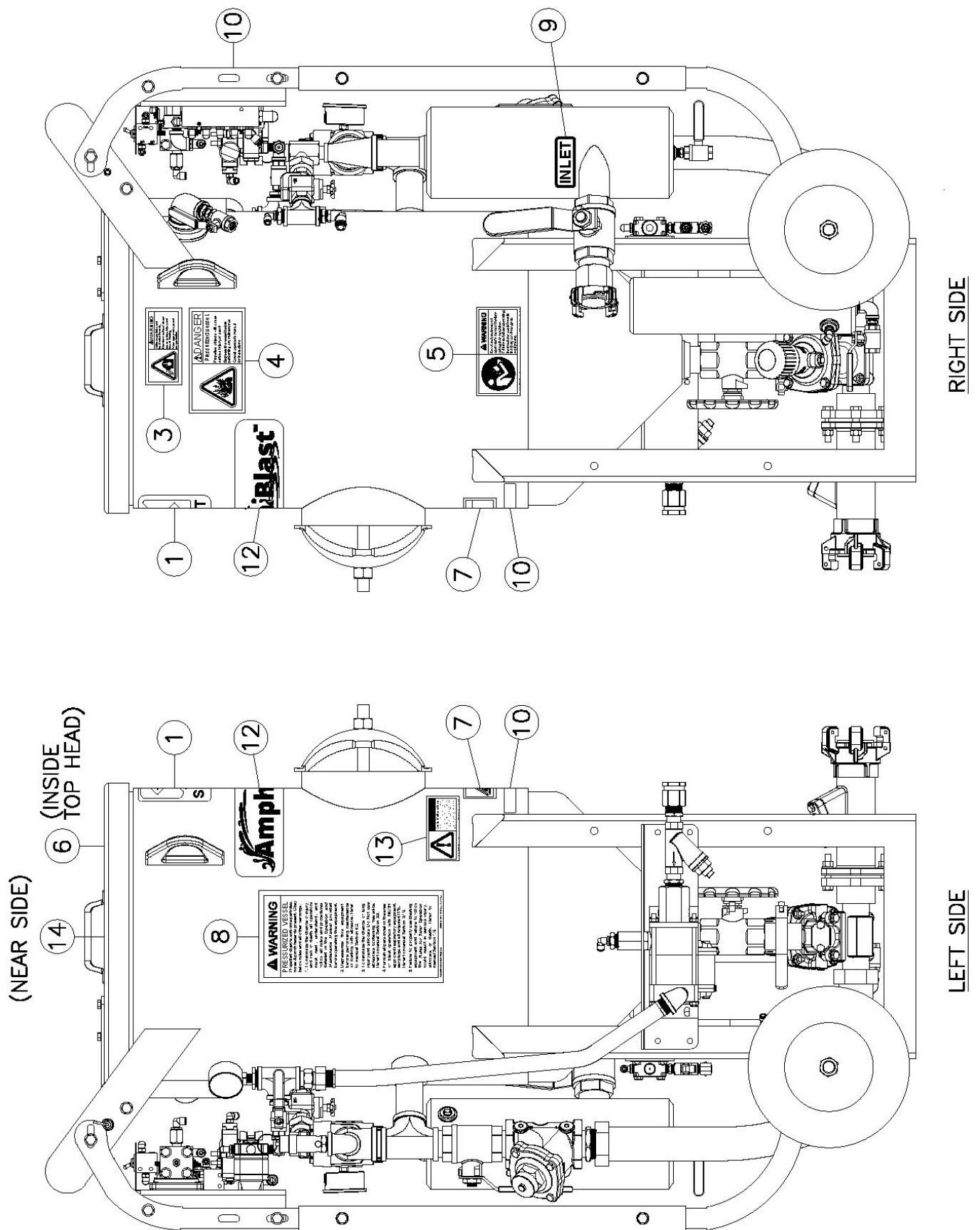

Figure 0.2 – Amphiblast™ 3.5 (1-Outlet) Warning Decal Placement

## Table of Contents

Section		Page
0.0	Warning Decal Identification and Location	4
1.0	Rules for Safer Operation	10
2.0	Specifications and General Information	17
3.0	Installation Requirements and Personal Protective Equipment	22
4.0	Abrasive Blast System General Operation	28
5.0	AmphiBlast™ System General Operation	29
6.0	Pre-operation Procedures	39
7.0	Operating Instructions	44
8.0	Maintenance and Inspection Instructions	53
9.0	Drawings and Parts Lists	59
10.0	Recommended Spare Parts Lists	80
11.0	Troubleshooting	81
12.0	Warranty and Reference Information	86
13.0	Blasting Data Tables	90
14.0	Water Pump Manual	91



THIS PAGE IS INTENTIONALLY BLANK

## 1.0 Rules for Safer Operation

### 1.1. GENERAL RULE FOR SAFER OPERATION.

SCHMIDT® ABRASIVE BLASTERS HAVE BEEN DESIGNED TO BE SAFE WHEN USED IN THE PROPER MANNER. ALL ABRASIVE BLASTERS ARE POTENTIALLY DANGEROUS IF ALL SAFETY PRECAUTIONS ARE NOT RIGOROUSLY FOLLOWED. PROPER TRAINING IS REQUIRED BEFORE OPERATION. PROPER PROCEDURES MUST BE FOLLOWED. THE ABRASIVE BLASTER AND ALL COMPONENTS MUST BE PROPERLY MAINTAINED. FAILURE TO OPERATE, SERVICE AND MAINTAIN THE ABRASIVE BLASTER AS SET FORTH IN THIS MANUAL MAY CAUSE INJURY OR EVEN DEATH TO ANY PERSON USING, SERVICING OR IN THE VICINITY OF THE ABRASIVE BLASTER.

THIS MANUAL IDENTIFIES POTENTIAL HAZARDS BY DANGER, WARNING, AND CAUTION SYMBOLS. HOWEVER, ALL THE RULES, PROCEDURES AND RECOMMENDATIONS MUST BE FOLLOWED. FAILURE TO OPERATE PROPERLY IS VERY LIKELY TO PLACE PERSONS AND PROPERTY AT HIGH RISK OF DAMAGE, INJURY OR EVEN DEATH.



ABRASIVE BLASTERS AND THE ABRASIVE BLAST OPERATION ARE POTENTIALLY DANGEROUS IF ALL SAFETY PRECAUTIONS ARE NOT FOLLOWED. FAILURE TO OPERATE THE ABRASIVE BLASTER WITHOUT FOLLOWING ALL THE *RULES FOR SAFER OPERATION* MAY RESULT IN SERIOUS INJURY OR DEATH TO OPERATING PERSONNEL OR PERSONS IN THE OPERATING VICINITY.

### 1.2. KNOW YOUR EQUIPMENT.

Do Not operate this equipment in a manner other than its intended application (see Section 4.0). Do Not operate this equipment or any other Schmidt® equipment without following the *Rules for Safer Operation* and all the operating procedures and instructions. Learn the applications and limitations as well as the specific potential hazards related to this machine. Failure to do so could result in serious injury or death.

### 1.3. RECEIVE PROPER TRAINING.

Do Not operate this equipment unless you have received operational and maintenance training. Begin by thoroughly reading and understanding this operation and maintenance manual and all included information. Consult an authorized Schmidt distributor or Axxiom manufacturing, Inc.

### 1.4. PROTECT YOUR FEET.

Do Not operate this equipment without wearing OSHA approved foot protection. Observe all applicable local, state and federal regulations. See Section 3.10 and OSHA 29 CFR 1910.136.



Heavy objects can shift while being blasted and may fall on operators. All operators and personnel in the vicinity must wear OSHA approved foot protection during the operation of this equipment. See Section 3.10 and OSHA 29 CFR 1910.136.

### 1.5. PROTECT YOUR EYES.

Do Not operate this equipment without wearing OSHA approved safety glasses. Observe all applicable local, state and federal safety regulations. See Section 3.10 and OSHA 29 CFR 1910.133.



When filling the blast vessel and during the blast operation, abrasive can be blown in the face and eyes of operators. All operators and personnel in the vicinity must wear OSHA approved safety glasses during the operation of this equipment. See Section 3.10 and OSHA 29 CFR 1910.133.

### 1.6. PROTECT YOUR LUNGS.

Do Not operate this equipment without wearing OSHA approved respiratory protection. Abrasive blasting produces dust contaminated with toxic substances from the abrasive used, the coating being removed, and the object being blasted. This dust may contain silica which can cause severe and permanent lung damage, cancer, and other serious diseases. Do Not breathe the dust. Do Not rely on your sight or smell to determine if dust is in the air. Silica and other toxic substances may be in the air without a visible dust cloud. If air-monitoring equipment for silica is not provided at the worksite, then all personnel **MUST** wear appropriate respiratory protection when using or servicing this equipment. Breathing air supplied to respirators must be of acceptable quality. Consult your employer and OSHA regarding the appropriate respiratory protection and breathing air quality. See Sections 3.9, 3.10, and OSHA 29 CFR 1910.134.



Abrasive blasting produces dust which may contain silica and other toxic substances that can cause severe and permanent lung damage, cancer, and other serious diseases if inhaled. All operators and personnel in the vicinity must wear OSHA approved respiratory protection during the operation of this equipment See Sections 3.9, 3.10, and OSHA 29 CFR 1910.134.

### 1.7. BREATHING AIR QUALITY.

Do Not use breathing air that does not meet OSHA Class D standards. Use extreme caution when selecting a source of breathing air. Breathing air provided by an oil-lubricated air compressor can contain carbon monoxide; therefore, use of a carbon monoxide detector is required (See Section 3.10). Carbon monoxide can be in the compressed air produced by an oil-lubricated air compressor when it is operated at extremely high temperature; therefore a high temperature alarm is required to alert the operators when this condition exists. See Section 3.9 and reference OSHA 29 CFR 1910.134(i).

Extreme caution must be taken when connecting to factory air sources. Factories can have sources of compressed gases such as nitrogen which is fatal if used as a breathing air source. Verify that the air source is breathable air.



Breathing air must meet OSHA Class D standards. Use of breathing air sources that do not meet Class D standards can cause asphyxiation and result in death. Verify that all air sources are breathable quality and use a high-temperature alarm and a carbon monoxide monitor when required. See Sections 3.9, 3.10 and OSHA 29 CFR 1910.134(i).

Enclosed blast areas must be ventilated to reduce airborne dust to an acceptable level as required by OSHA 29 CFR 1910.1000.

**1.8. PROTECT YOUR HEARING.**

Do Not operate this equipment without wearing OSHA approved hearing protection. Observe all applicable local, state and federal safety regulations. See Section 3.10 and refer to OSHA 29 CFR 1910.95.



Loud noise is produced by the blast nozzle and the blowdown operation of this equipment. All operators and personnel in the vicinity must wear OSHA approved hearing protection during the operation of this equipment. See Section 3.10 and refer to OSHA 29 CFR 1910.95.

**1.9. PROTECT YOUR PERSON**

Abrasive blasting produces dust contaminated with toxic substances from the abrasive used, the coating being removed, and the object being blasted. All blast operators and other personnel involved in the blast operation or in the vicinity of the blast operation should wear protective clothing. The protective clothing should be disposable or washable work clothes that should be removed at the worksite so that contaminated dust is not transferred into automobiles or homes. See Section 3.10 and refer to OSHA 29 CFR 1910.94 and 1910.132.

**1.10. ADHERE TO ALL REGULATIONS.**

Do Not operate this equipment without observing all local, state, and federal safety regulations including, but not limited to, OSHA (Occupational Health and Safety Administration).

**1.11. STAY ALERT.**

Do Not operate this equipment when you are tired or fatigued. Use caution and common sense while operating and/or performing maintenance on this equipment.

**1.12. DO NOT USE DRUGS, ALCOHOL, or MEDICATION.**

Do Not operate this equipment while under the influence of drugs, alcohol, or any medication.

**1.13. PROTECT BYSTANDERS.**

Do Not allow blast equipment operators and other personnel to enter the vicinity of the blast operation without providing respiratory protective equipment that meets OSHA regulations. If dust concentration levels exceed the limitations set in OSHA 29 CFR 1910.1000 then respirators are required.

**1.14. KEEP CHILDREN AND VISITORS AWAY.**

Do Not allow children or other non-operating personnel to contact this equipment or the connecting hoses and cords. Keep children and non-operating personnel away from work area.

**1.15. AVOID DANGEROUS ENVIRONMENTS.**

Do Not operate this equipment without familiarizing yourself with the surrounding environment. The blast operation creates high level of noise which may prevent the operator from hearing other possible dangers (i.e. traffic or moving equipment). In such situations a stand-by watch person may be necessary to protect against injury to personnel.

**1.16. AVOID DANGEROUS ENVIRONMENTS.**

Do Not use this equipment in areas cluttered with debris. Debris in the work area can create tripping hazards which can cause the operator to lose control of the blast hose and result in injury to operating personnel. Keep work area clean and well lit. When working at an elevated location, pay attention to articles and persons below.

**1.17. AVOID DANGEROUS ENVIRONMENTS.**

Do Not operate this equipment in elevated areas without using fall protection equipment. Certain applications of this equipment may require the use of scaffolding. Use of scaffolding creates hazardous situations such as tripping and fall hazards which can result in serious injury or death to operating personnel. Consult OSHA 29 CFR 1910 Subpart D.

**1.18. AVOID DANGEROUS ENVIRONMENTS.**

Do Not blast objects that are not properly secured. The blast operation can cause the blasted object to shift or move. Extremely large objects to be blasted can create a crush hazard to operating personnel which can result in serious injury or death. Properly secure the object to be blasted.

**1.19. AVOID DANGEROUS ENVIRONMENTS.**

Do Not blast objects used to store flammable materials. The blast operation can cause sparks which can ignite fumes or residual flammable materials inside enclosed containers which can explode resulting in serious injury or death to operating personnel.

**1.20. AVOID DANGEROUS ENVIORNMENTS**

It has been determined that blast abrasives approved for use in blast equipment are not ignitable nor do they present a dust explosion hazard in environments approved for use. However; airborne substances that make up the items and substrates being blasted can be ignitable when mixed with airborne dust from the blast abrasive. To mitigate risk of dust explosion avoid blasting in confined spaces without proper ventilation. Consult plant authorities, OSHA 29 CFR 1910.146 and 1910-94.



Explosion Hazard. Do Not operate blast equipment in confined spaces without proper ventilation. Consult plant authorities, OSHA 29 CFR 1910.146 and 1910.94.

**1.21. ELECTRICALLY GROUND EQUIPMENT.**

Static electricity is generated by the abrasive flow through the blast hose and/or vacuum hose. To minimize chance of static electrical shock to operating personnel only use anti-static blast hose and/or vacuum hose, properly electrically bond the blast nozzle, blast hose couplings, and the equipment, and properly install a earth ground to the abrasive blaster. See Section 5.12.

**1.22. MAINTAIN VESSEL INTEGRITY.**

Do Not operate this equipment with the pressure vessel damaged, or with any part of it worn or damaged. Do Not operate this equipment in a condition that may cause failure of the pressure vessel. See Sections 1.23 through 1.33 below.



An abrasive blaster is a Pressurized Vessel. Alterations, damage, or misuse of the pressure vessel can result in rupturing. Damaged or incorrect components used on the abrasive blaster can result in rupturing. The compressed air inside a pressurized vessel contains a dangerously high level of energy which can propel objects and cause serious injury or death.

**1.23. NEVER OPERATE OVER MAXIMUM WORKING PRESSURE.**

Do Not operate this equipment above maximum allowable working pressure (MAWP) at maximum operating temperature (°F) shown on the ASME nameplate attached to the vessel. See Sections 2.2 and 8.1.

**1.24. INSTALL PRESSURE RELIEF DEVICE.**

Do Not operate this equipment without a pressure relief device in place. The ASME Code requires that all vessels be equipped with pressure relief devices prior to installation. The pressure relief device must be set at the maximum allowable working pressure of the abrasive blaster. See the ASME nameplate attached to the vessel. See Section 3.11 for information regarding the pressure relief valve.

**1.25. NEVER OPERATE BEYOND ALLOWABLE TEMPERATURE RANGE.**

Do Not operate this equipment above the maximum allowable temperature at the allowable pressure or below the minimum design metal temperature (MDMT) shown on the pressure vessel nameplate. The characteristics of the pressure vessel metal are weakened when the temperature is outside the operating range. Operating the pressure vessel outside of allowable temperature range can result in rupturing and cause serious injury or death. See Section 2.2.

**1.26. ASME NAMEPLATE REQUIRED.**

Do Not operate this equipment if the ASME pressure vessel nameplate is missing. Contact Axxiom Manufacturing, Inc. for technical support.

**1.27. DO NOT MODIFY VESSEL.**

Do Not modify or alter any abrasive blaster, blast equipment, or controls thereof without written consent from Axxiom Manufacturing, Inc. Do Not weld, grind, or sand the pressure vessel. *It will not be safe to operate.* Non-authorized modifications could lead to serious injury or death. Non-authorized modifications will void the warranty and may void the ASME/NB integrity.

**1.28. DO NOT HAMMER ON VESSEL.**

Do Not hammer on or strike any part of the pressure vessel. Hammering on the pressure vessel can create cracks and cause rupturing.

**1.29. FIRE DAMAGE NOTICE.**

Do Not operate if the pressure vessel has been damaged by fire. If damaged, take out of service immediately and have it inspected and/or repaired by a qualified facility. Contact Axxiom Manufacturing, Inc. for technical support.

**1.30. INSPECT VESSEL REGULARLY.**

Do Not operate this equipment with damage to the pressure vessel. *It is not safe.* Inspect outside and inside of the pressure vessel regularly for corrosion or damage (i.e. dents, gouges or bulges). If damaged, take out of service immediately and have it inspected and/or repaired by a qualified facility. Contact Axxiom Manufacturing, Inc. for technical support. See Section 8.0.

**1.31. CHECK FOR LEAKS IN VESSEL.**

Do Not operate this equipment if there is a leak in the pressure vessel. If leaking, take out of service immediately and have it inspected and/or repaired by a qualified facility. Contact Axxiom Manufacturing, Inc. for technical support.

**1.32. INSPECT HANDWAY ASSEMBLY.**

Do Not operate the abrasive blaster without first inspecting the handway assembly. To insure proper operation all handway components must be the correct size for the vessel handway opening. See Section 6.4.

**1.33. NEVER MODIFY BLOWDOWN.**

Do Not connect the blowdown on this equipment onto a common header with any other unit of any description, or any other source of compressed air, without first making sure a check valve is used between the header and this unit. Do Not install this equipment sharing piping with another unit of higher discharge pressure and capacity. A safety hazard could occur in the form of a back-flow condition. Do Not install a muffler or silencer on the blowdown that is not designed for use on abrasive blast equipment it can cause a malfunction and can result in a hazardous condition. See Section 5.5 and Section 6.2.

**1.34. DEPRESSURIZE VESSEL BEFORE PERFORMING MAINTENANCE.**

Do Not remove, repair, or replace any item on this equipment while it is pressurized. Do Not attempt to perform maintenance or load abrasive while this equipment is pressurized or is even capable of being pressurized. This means the inlet ball valve should be closed and the air supply should be shut off or disconnected. Anytime the manual blowdown valve is closed it should be assumed that the abrasive blast vessel is pressurized.



An abrasive blaster is a Pressurized Vessel. The compressed air inside a pressurized vessel contains a dangerously high level of energy which can propel objects and cause serious injury or death. Depressurize vessel before performing any maintenance. See Section 6.2.

**1.35. ALWAYS USE REMOTE CONTROLS.**

Do Not sell, rent, or operate abrasive blasters without remote controls. OSHA regulations require remote controls on all abrasive blasters. All abrasive blasters must be equipped with automatic (deadman) type remote controls (either pneumatic or electric). Failure to use remote controls can cause serious injury or death to the operator(s) or other personnel in the blasting area. Reference OSHA 29 CFR 1910.244(b).

**1.36. NEVER USE BLEEDER TYPE DEADMAN VALVES.**

Do Not use bleeder type deadman valves on any Schmidt® abrasive blaster. The use of A-BEC, Clemco, or a similar bleeder type deadman valve can, without warning, cause unintentional start-up which can result in serious personal injury. A particle of dirt from the air hose can plug the bleed hole in the deadman valve and cause the blast outlet to turn on.

**1.37. CHECK FOR DAMAGED PARTS.**

Do Not use this equipment with damaged components. Periodically check all valves, hoses, fittings, pipe, and pipe fittings (internal and external) to confirm that they are in good condition. Repair or replace any component that shows any sign of wear, leakage, or any other damage. See Section 8.0.



Damaged components can fail during operation and result in serious injury or death to operating personnel.

**1.38. ALWAYS USE SAFETY PINS ON HOSE COUPLING CONNECTIONS.**

Do Not use this equipment without hose coupling safety pins in place and hose whip checks installed on all air and blast hoses. All blast hose couplings and air hose couplings have pin holes that must be safety pinned to protect against accidental disconnections. Accidental hose disconnection can cause serious injury or death. See Sections 5.14 and 8.7.

**1.39. ALWAYS USE CORRECT REPLACEMENT PARTS AND ACCESSORIES.**

Do Not use replacement parts or accessories that are not rated for pressures equal to or higher than the abrasive blaster's operating pressure. Improper hoses and/or fittings used on, or connected to the abrasive blaster can rupture and cause serious injury or death.

Do Not use replacement parts that are not Schmidt® original factory replacement parts. Non-original parts may not fit properly and can cause equipment damage and/or failure which can result in serious injury to operating personnel. Consult Axxiom Manufacturing, Inc. See Section 9.0 and Section 12.2.12.



Use of replacement components that are not Schmidt® original factory replacement parts may result in equipment failure which can result in serious injury to operating personnel.

**1.40. ALWAYS USE CORRECT PRESSURE RATED ACCESSORIES.**

Do Not use air reservoirs or moisture separator tanks that are not rated for use in compressed air applications. Air reservoirs and moisture separator tanks larger than 6 inches inside diameter must have an ASME code stamp.



An air reservoir or moisture separator tank is a Pressurized Vessel. The compressed air inside a pressurized vessel contains a dangerously high level of energy which can explode propelling objects and result in serious injury or death to operating personnel. Air reservoirs and moisture separator tanks must be ASME coded tanks.

**1.41. NEVER AIM BLAST NOZZLE TOWARDS ANY PERSON.**

Do Not aim the blast nozzle towards yourself or any person. A system malfunction or a blocked blast nozzle that clears can trigger accidental start up resulting in injury to personnel.

**1.42. NEVER USE ABRASIVE NOT INTENDED FOR BLAST EQUIPMENT.**

Do Not use abrasive blast media containing free silica. Silica can cause silicosis or other related respiratory damage. Verify that the abrasive is intended for use in blasting equipment. Personal protective equipment, including airline filters and respirators, must be used for all abrasive blasting operations. Observe all applicable local, state and federal safety regulations. See Sections 3.8, 3.10, and reference OSHA 29 CFR 1910.134.

**1.43. CHECK ABRASIVE FOR DEBRIS.**

Do Not use blast abrasive that contains trash or other debris. Trash or debris can create a blockage and cause equipment malfunction. Screen recycled abrasive to remove trash.

**1.44. STOP OPERATION IMMEDIATELY IF ANY ABNORMALITY IS DETECTED.**

Do Not operate this equipment if anything abnormal is seen during operation. Stop operation immediately for inspection. Refer to Section 8.0 for maintenance and inspection details.

**1.45. DO NOT OVERLOAD THE LIFT EYES.**

Do Not load the lifting eyes above the rated capacity. Do Not lift this equipment by any point other than the lifting eyes or designated lift points. Do Not lift this equipment while it is pressurized. See Section 2.6.

**1.46. MAINTAIN WARNING DECALS.**

Do Not remove, cover, obstruct, or paint over any warnings, cautions, or instructional material attached. Warning decals must be installed, maintained, and located to be visible and with enough light for legibility. See Sections 0.0 and 8.14.

**1.47. SAVE THIS OPERATION AND MAINTENANCE MANUAL.**

Refer to this operation and maintenance manual as needed as well as any additional information included from other manufacturers. Never permit anyone to operate this equipment without having him/her first read this manual and receive proper training. Make this manual readily available to all operating and maintenance personnel. If the manual becomes lost or illegible replace it immediately. This operation and maintenance manual should be read periodically to maintain the highest skill level; it may prevent a serious accident. This operation and maintenance manual is available for downloading from [SchmidtAbrasiveBlasting.com](http://SchmidtAbrasiveBlasting.com).

**1.48. SAFETY REFERENCES**

See Section 12.4 for safety information sources and contact information. Use these sources to obtain additional information regarding all aspects of blast operation safety.



## 2.0 Specifications and General Information

### 2.1 Notes to Distributors and Owners

- 2.1.1. Verify that the deadman, twinline (or cords), and the operation and maintenance manual are included with the abrasive blaster when it is received. Verify that the deadman, twinline (or cords), and the operation and maintenance manual are included with the abrasive blaster when it is delivered to the purchaser.
- 2.1.2. This equipment is intended for knowledgeable and experienced users. No person or persons should be allowed to operate this equipment without first receiving proper training in abrasive blasting operation and use of this equipment.
- 2.1.3. Immediately notify Axxiom Manufacturing, Inc. of any instances of use of this equipment in any manner other than the intended application. See Section 4.0.
- 2.1.4. Only qualified personnel should load and unload this equipment for shipping. Slings or other lifting devices must only be attached to the designated lifting points. See the lifting diagrams shown in Section 2.6.
- 2.1.5. For further information on options and accessories available for Schmidt® abrasive blasters visit the Axxiom website or contact us:

Axxiom Manufacturing, Inc.  
 11927 South Highway 6  
 Fresno, Texas 77545  
 Phone: 1-800-231-2085  
 Fax: 1-281-431-1717  
 Website: [www.SchmidtAbrasiveBlasting.com](http://www.SchmidtAbrasiveBlasting.com)

### 2.2 Abrasive Blaster Operational Specifications

Maximum Working Pressure	150 psig @ 250°F (see ASME nameplate).
Maximum External Pressure	Not designed for external pressure
Minimum Metal Temperature	-20°F @ 150 psig (see ASME nameplate)
Air Consumption	See Section 13.0 table 1
Abrasive Consumption	See Section 13.0 table 2
Blast Hose Size	See Section 13.0 table 3
Electrical requirements	See Section 3.7
Abrasive Capacity	Model 3.5: 3.1 cu.ft
ATEX Operating Temperature	-20°F < Operating Temperature < 122°F

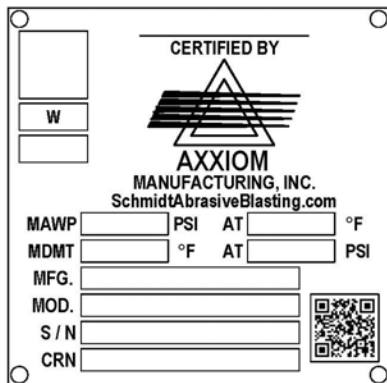

ASME Nameplate

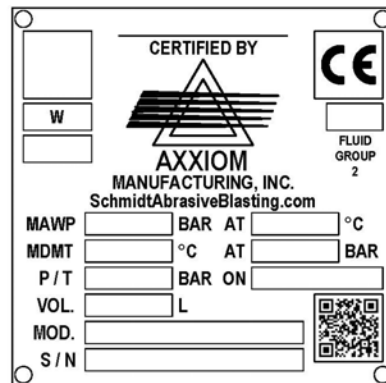

ASME/CE Nameplate

### 2.3 Important Reference Numbers

Fill in the Abrasive Blaster model number, serial number, and other information in the blank spaces below. This information will be needed for reference when service, maintenance, or technical support is required. See pressure vessel nameplate for the below indicate identification numbers. See Section 2.2.

Blaster Model Number \_\_\_\_\_

Blaster Serial Number \_\_\_\_\_ National Board Number \_\_\_\_\_

Blaster Type: *Tera Valve* Blaster Piping Size \_\_\_\_\_

### 2.4 Vessel Information

2.4.1. All pressure vessels used in Schmidt® Abrasive Blasters are manufactured in strict accordance with the provisions of the ASME Code Section VIII, Div. 1.

2.4.2. In order to maintain the high level of quality and quality control used in the manufacture of this vessel, it is required that any and all welded repairs to this vessel be performed by a reputable shop holding a National Board “R” Stamp and/or an ASME “U” stamp, depending on state or city law. Welding on the vessel performed by welders not properly qualified per the ASME Code may void the ASME/NB integrity of the vessel.

### 2.5 Notes

---

---

---

---

---

---

---

---

## 2.6 AmphiBlast™ Lifting Diagram and Dimensional Specifications

**⚠ DANGER**

An abrasive blaster is a Pressurized Vessel. The compressed air inside a pressurized vessel contains a dangerously high level of energy which can propel objects and cause serious injury or death. Depressurize vessel before lifting, moving, or transporting. See Section 6.2

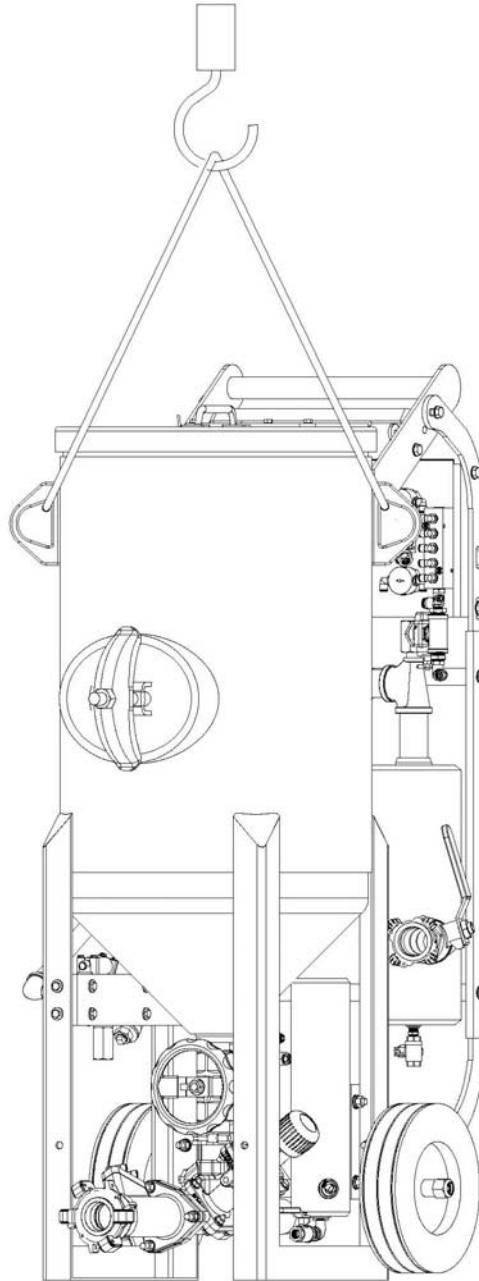

**NOTE: EMPTY LIFT ONLY. DO NOT LIFT WITH ABRASIVE.**

**Figure 2.6(a) – AmphiBlast™ 3.5 (1-Outlet) Lifting Diagram**

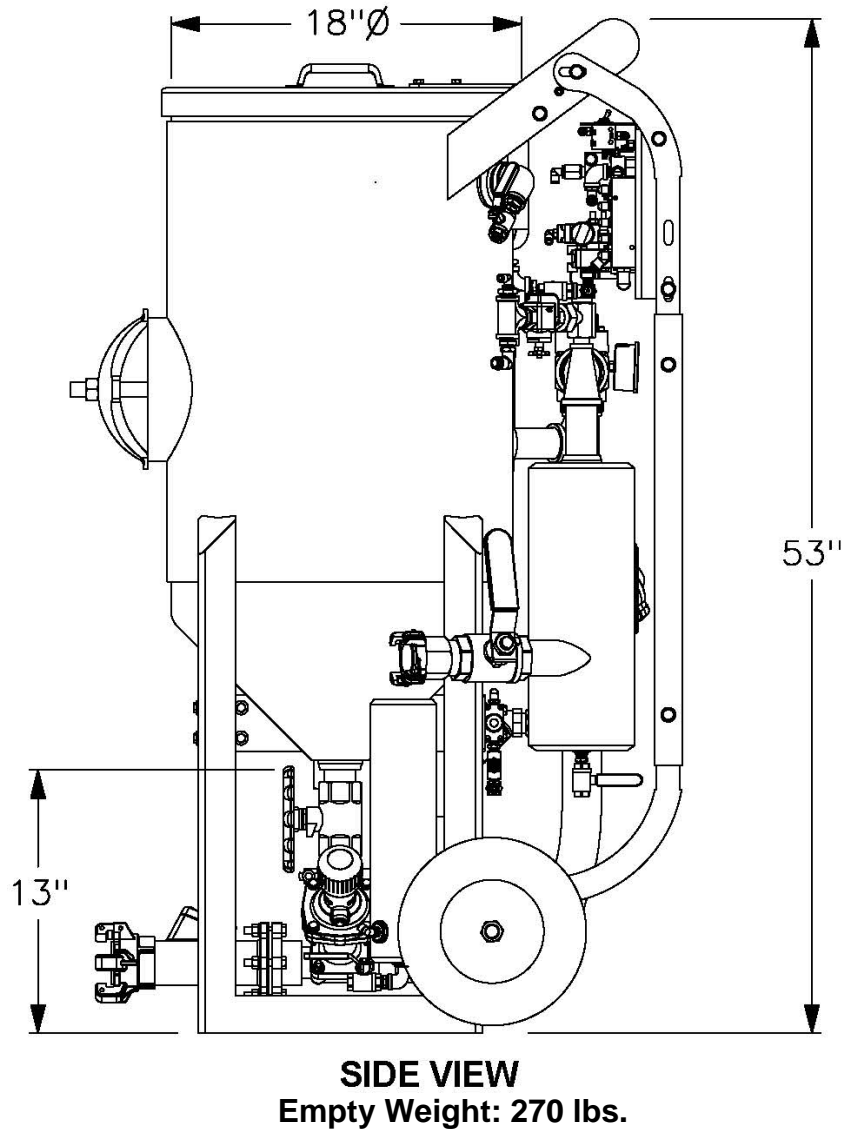
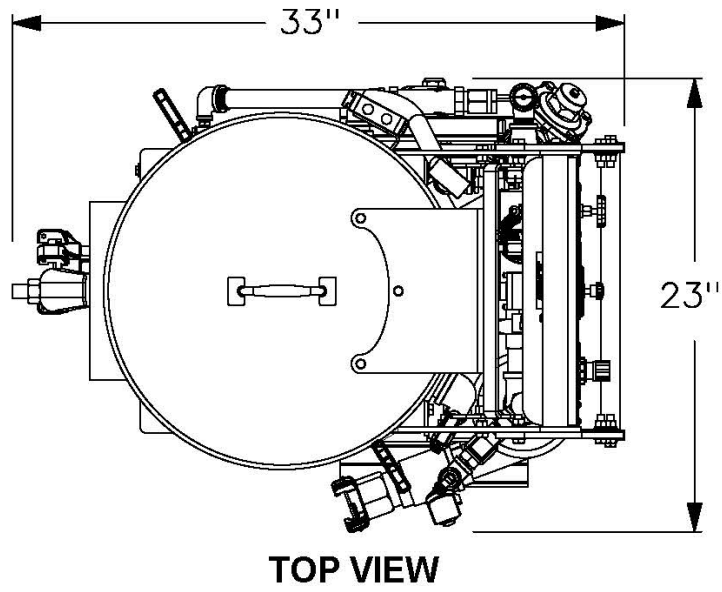

**Figure 2.6(b) – AmphiBlast™ 3.5 (1-Outlet) Dimensional Data**

## 2.7 AmphiBlast™ Packing Detail

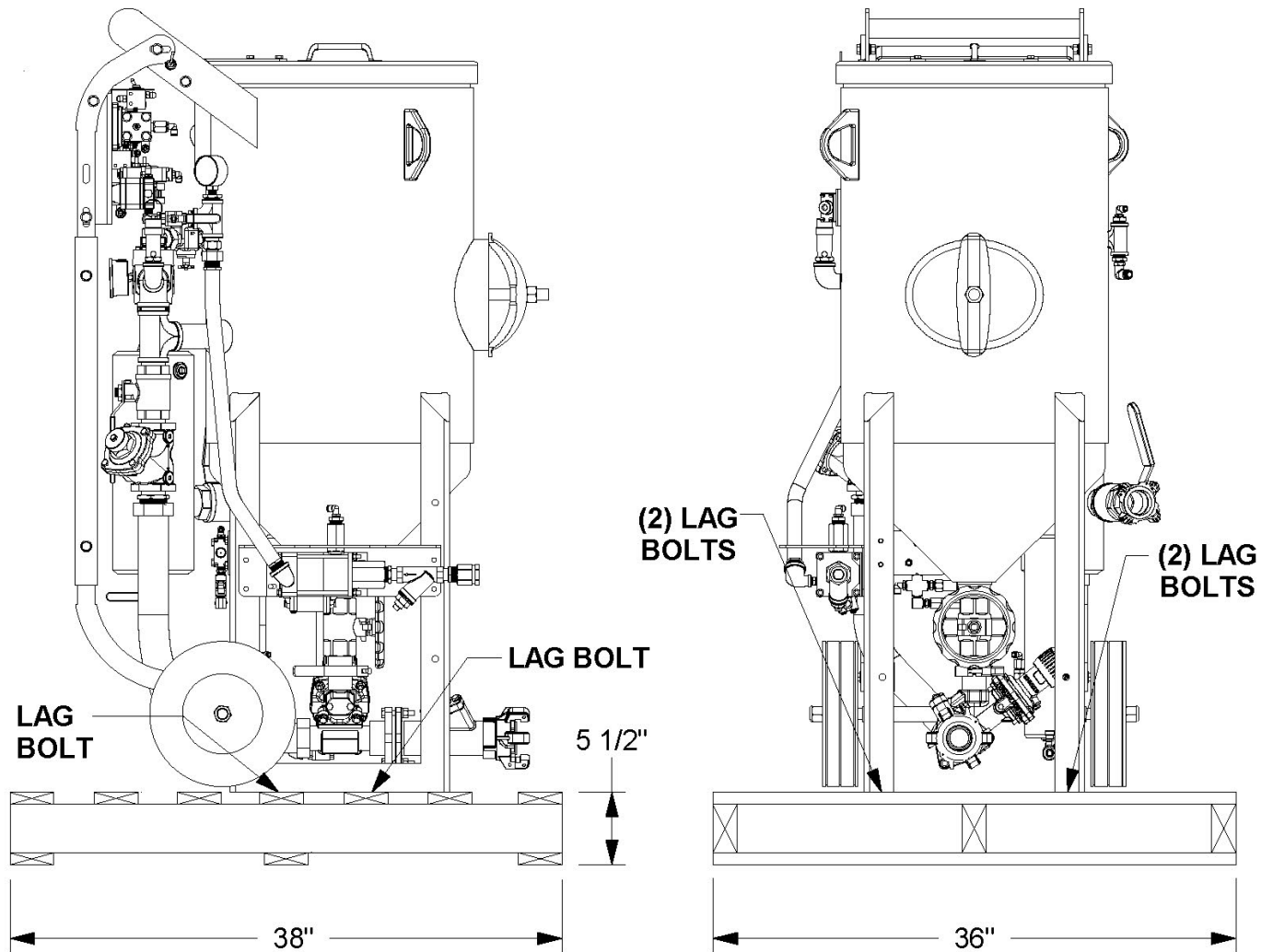

**POSITION BLASTER AS SHOWN TO PROTECT PIPING.  
LAG BOLT BLASTER TO PALLET AS SHOWN.  
EMPTY WEIGHT WITH PALLET = 308 LBS.**

**Figure 2.7 – AmphiBlast™ 3.5 (1-Outlet) Shipping Detail**

## 3.0 Installation Requirements and Personnel Protective Equipment

Carefully read and follow all the recommendations regarding the abrasive blast system installation requirements. Improper installation can result in equipment malfunction and significant lost time expenses. Consult an authorized Schmidt® distributor or Axxiom Manufacturing, Inc.

### 3.1 Abrasive Blast System Installation Location

- i. *Portable units:* Units equipped with handles and wheels are portable and can be rolled to locations where blast jobs are performed. Locate the unit to allow accessibility to the handway and for ease of abrasive filling. Pay close attention to objects that may be in the path of the pressure vessel exhaust air (depressurization). See Section 6.2 for system depressurization.
- ii. *Stationary units:* Units that will be installed in permanent locations require careful consideration. Stationary units can be installed below an abrasive hopper with a support structure that can limit access to the abrasive blast system. Install stationary blast systems in a position that will allow access to the handway and the blaster piping. These areas must be accessible to perform required maintenance. Pay close attention to objects that may be in the path of the pressure vessel exhaust air (depressurization). See Section 6.2 for system depressurization. An exhaust hose assembly can be installed on an AmphiBlast™ to direct the exhaust air into the blast room. **Note:** A longer blowdown exhaust hose can lengthen the blowdown time and also creates the possibility of blockage. **Note:** An abrasive spider is recommended for blasters installed below an abrasive hopper (see Section 9.12).

### 3.2 Compressed Air Requirements (blast nozzle)

The blast nozzle size and blast pressure determine the compressed air requirements. Available air flow capacity and/or air compressor size must be considered before selecting the blast nozzle size. An air source dedicated to the abrasive blast system is preferred to reduce system pressure drops and back flow of air. If an existing air compressor will be used or a limited air supply is available, then the blast nozzle must be selected based on these conditions. Be aware that as the blast nozzle wears the air demand will increase. See Table 1 in Section 13.0 for air consumption by nozzle size at various pressures.

### 3.3 Air Compressor Size

Air compressor size is crucial to the operation of the abrasive blast system. Blast nozzle selection and desired productivity must be evaluated to determine the air flow requirements prior to selecting the air compressor size. Sufficient air supply capacity is necessary to maintain the system air pressure. Insufficient air flow capacity will result in reduced blast nozzle pressure and lost productivity. The air compressor must be large enough to supply:

- i. The sum of blast air requirements for each nozzle at the highest pressure that will be used (see Section 13.0, Table 1).
- ii. The 12 CFM breathing air supplied to each blast operator respirator. **Note:** Reference OSHA regulations regarding requirements for breathing air, especially when an oil-lubricated air compressor is used.

### 3.4 Blast System Air Supply Line

The air supply hose and fittings must be rated at a minimum of 150 psi operating pressure. The air supply hose from the air compressor to the blast unit should be at least the same diameter as the air inlet piping (see Section 9.0). This size hose will be large enough to supply the required airflow to operate the blast unit controls and each blast nozzle. See Section 5.14 for further information on air hose connection.

**Note:** If the abrasive blast system will be installed in a permanent location, the inlet connection can be hard piped. Do Not install hard piping that is smaller than the piping size of the blast system. Smaller piping size will reduce the air flow capacity. If other equipment will be using the same source of air as the abrasive blaster, install a check valve at the air inlet. This will protect against back flow of air pressure that can carry abrasive into the blast controls.

Hard piping connected to the abrasive blaster must be structurally supported so not to apply any loading on the pressure vessel at the points of connection. Unsupported piping can create bending loads at the pressure vessel connections which can cause damage and possible failure. Hard piping connections to the pressure vessel must be designed and installed by qualified personnel experienced with piping systems and the applicable codes pertaining to them.



External loading at piping connection can cause damage and possible failure of the pressure vessel. Hard piping connected to the pressure vessel must include supports to eliminate the possibility of applying a load on the pressure vessel.

### 3.5 Blast System Air Pressure

The maximum allowable working pressure (MAWP) for the blast unit is stamped on the ASME nameplate attached to the vessel. For most abrasive blast systems the MAWP is 150 psig. Do Not exceed the MAWP. **CRITICAL: Any inlet air valve or air pressure regulator added to the system must have sufficient air flow capacity for proper operation of the blast system. Insufficient air flow capacity will cause pressure drop in the blast system resulting in equipment malfunction, abrasive backflow, and reduced blast productivity. Select a valve that will operate with little or no pressure drop (5 psi max.) at the required cfm air flow.**

### 3.6 Blast System Air Quality

Air quality is crucial to the operation of an abrasive blaster. Moisture and contaminants can cause components to malfunction. Moisture condensation in a blast system causes abrasive flow problems. Condensation occurs when the hot vapor-filled compressed air cools as it reaches the abrasive blaster. Water droplets formed during condensation can be absorbed by the abrasive in the blast vessel which can cause erratic flow to the abrasive valve. To minimize the chance of abrasive flow problems a moisture removal device installed for the blast system air supply is highly recommended (i.e. coalescing moisture separator, air-cooled aftercooler or deliquescent dryer). Contact a local authorized Schmidt® distributor or Axxiom Manufacturing, Inc. to locate one near you.

### 3.7 Electrical Requirements

On units equipped with electric blast controls the supply voltage is 12Vdc or 24Vac. The maximum power required is:

1-outlet with abrasive cutoff: 7 watts

**Note:** Insufficient electric power output will result in malfunctioning of the electric blast control system. A power transformer or power supply can be used if the above voltages are not readily available.

### 3.8 Abrasive Selection

Abrasive selection is likely the most difficult decision related to the blast operation. Choice of abrasive is based on factors such as blast application type, desired finish and coating requirements, characteristics of object to be blasted, cost and ability to recycle, available equipment, safety, and environmental constraints.

There are many abrasives available that are either natural, manufactured, or processing by-products. Abrasives are available in varying sizes, shapes, and hardness. These characteristics determine the resulting effect on the surface to be blasted and limitations of its use. The effects on the blasted surface are measured by its degree of cleanliness and the surface profile. Standards and required levels of these measurements are established by organizations such as Steel Structures Painting Council (SSPC), National Association of Corrosion Engineers (NACE) and coating manufacturers. See Section 12.5 for contact information of these organizations. Use these sources to obtain information regarding all aspects of surface preparation and abrasive selection guidelines.

Schmidt® abrasive blasters are designed for high production open abrasive blasting with a wide range of abrasives. It is the responsibility of the employer and operators to select the proper abrasive. It is the responsibility of the employer to make certain that the abrasive selected is safe to use for abrasive blasting.

**Critical:** Always obtain the Material Safety Data Sheet (MSDS) for the abrasive to be used. The MSDS provides the chemical makeup of the abrasive. Do Not use abrasives containing toxic materials. Refer to OSHA 29 CFR for acceptable limits of various toxic substances and additional measures to be taken to protect operating personnel. Always use abrasives containing less than 1% of crystalline silica. Always use a NIOSH approved respirator when handling, loading and cleaning up abrasives. Organic substances which are combustible may only be used in automated blast systems with ventilation that meets OSHA 29 CFR 1910.94.

### 3.9 Breathing Air Quality

All blast operators must be supplied with and required to use NIOSH approved air-fed respirators. Breathing air supplied to these respirators must meet Grade D air quality standards as specified by OSHA 29 CFR 1910.134(i) and the Compressed Gas Association Specifications ANSI/CGA G-7.1. Consult these specifications when selecting a source of breathing air.

Breathing air must be clean, dry, contaminant-free, and provided at a pressure and volume specified by NIOSH. Use NIOSH approved air filters on all sources of breathing air. See Section 3.10.



Breathing air filters do not remove carbon monoxide or any other toxic gases. Use a carbon monoxide monitor to detect unacceptable levels. Consult OSHA 29 CFR 1910.134(i).

Many sources of breathing air are available such as air cylinders, free-air pumps, oil-less air compressors, and oil lubricated air compressors. The most commonly used is the same air compressor that is used for the blast air which most often is oil lubricated. Breathing air provided by an oil-lubricated air compressor can contain carbon monoxide and therefore requires the use of a carbon monoxide detector (See Section 3.10). Carbon monoxide can be in the compressed air produced by an oil-lubricated air compressor when it is operated at extremely high temperature; therefore, a high temperature alarm is required to alert the operators when this condition exists.



Oil lubricated air compressors can produce carbon monoxide. Carbon monoxide can cause asphyxiation and result in death. Use a high-temperature alarm and a carbon monoxide monitor when an oil lubricated air compressor is used to supply breathing air. Consult OSHA 29 CFR 1910.134(i).



### 3.10 Personal Protective Equipment (PPE)

Abrasive blasting has many hazards that may cause injuries to operators. To protect operators from injury each must be supplied with and required to use Personal Protective Equipment. The Occupational Health and Safety Administration (OSHA) requires the employer to assess the workplace to determine what PPE is necessary and supplied to each operator (Reference 29 CFR 1910 Subpart I). OSHA requires that this equipment meet or be equivalent to standards developed by the American National Standards Institute (ANSI). Figure 3.10 below identifies the minimum personal protective equipment required for each abrasive blast operator. Also identified are the OSHA references for each and the ANSI standard each PPE item must meet. All PPE clothing and equipment should be selected for safe design and quality of construction. Select each for proper fit and for comfort which will encourage operator use.



**Safety Glasses**

Reference OSHA 29 CFR 1910.133  
Must meet ANSI Z87.1



**Safety Boots**

Reference OSHA 29 CFR 1910.136  
Must meet ANSI Z41.1



**Ear Plugs**

Reference OSHA 29 CFR 1926.101  
Must meet ANSI S3.19  
(Also see OSHA 29 CFR 1910.95)

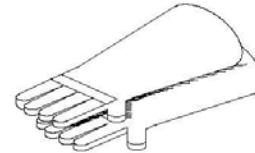

**Gloves**

Reference OSHA 29 CFR 1910.138  
No Applicable ANSI Standard

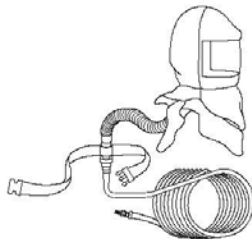

**Respirator**

Reference OSHA 29 CFR 1910.134  
Must be NIOSH approved



**Protective Clothing**

Reference OSHA 29 CFR 1910.132  
No Applicable ANSI Standard

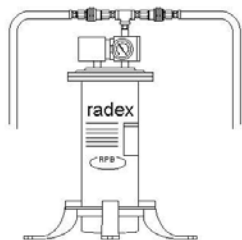

**Airline Filter**

Reference OSHA 29 CFR 1910.134  
Must be NIOSH approved

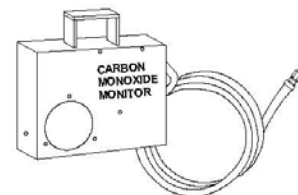

**Carbon Monoxide Monitor**

Reference OSHA 29 CFR 1910.134

**Figure 3.10 - Personal Protective Equipment**

### 3.11 Pressure Relief Valve Installation

Do Not operate this equipment without a pressure relief device installed to protect the blaster pressure vessel from over-pressurization. The ASME Code requires that all vessels be operated with pressure relief devices in place.

Local regulations set the specifications for pressure relief valves; therefore, it is the responsibility of the owner of the abrasive blaster to install a pressure relief valve that meets *all* applicable regulations. The pressure relief device must be set at the maximum allowable working pressure of the abrasive blaster pressure vessel. See the ASME vessel nameplates attached to the pressure vessel.

**⚠ DANGER**

Rupture Hazard. Operating the pressure vessel above the maximum allowable working pressure can result in rupturing the pressure vessel. Install an air pressure relief valve to protect against over pressurization of the blast vessel.

**⚠ WARNING**

Airborne particles and loud noise hazards from relief valve exhaust air can cause serious injury and loss of hearing. Wear approved eye and ear protection. Stay clear of exhaust air path. DO NOT place hands or other body parts in the exhaust air path. Make sure no personnel are in the exhaust air path. Direct the relief valve exhaust away from work area.

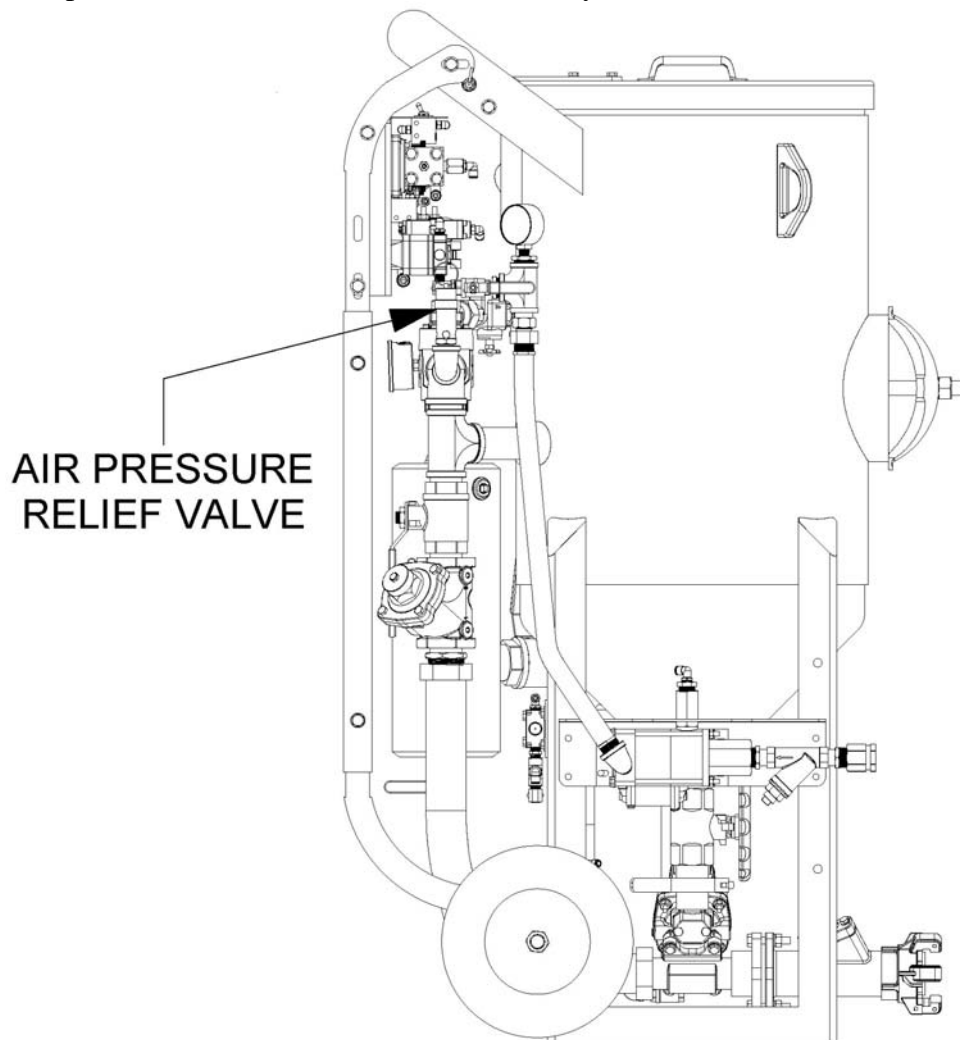

**Figure 3.11 – Location for Air Pressure Relief Valve**

### 3.12 INSTALLATION CHECKLIST (Photocopy this page to use as a worksheet)

- Deadman/Twinline (or cords):** confirm delivery with the abrasive blaster.
- Blast accessories:** confirm receipt as purchased with the blaster.
- Inspect blaster:** check for possible damage during shipment. See Section 8.0 for inspection instructions.
- Popup alignment:** remove popup dust cover from top head and check popup alignment. Shifting of popup is possible during shipment. See Section 8.4 for inspection & alignment instructions.
- Clean blaster:** remove handway cover and check for debris inside. Trapped debris can vibrate loose during shipment and later block abrasive flow. If necessary vacuum the bottom of tank. Replace handway cover per instructions in Section 6.4.
- Accessible location:** install stationary blasters so that handway is accessible for maintenance. See Section 3.1 for additional information.
- CFM available:** determine available air supply (cfm) and record here. \_\_\_\_\_  
See Sections 3.2, 3.3, and 3.5 for information on determining air requirements.
- Air supply connection:** install air supply piping or connect an air supply hose that is the same size as the blaster piping size or larger. See Section 3.4 for details.
- Air quality:** install moisture separator or AirPrep System to remove moisture from blast air supply to protect against abrasive flow problems. See Section 3.6.
- Electric power:** provide power source for electric deadman controls. See Section 3.7.
- Blast abrasive:** select abrasive suited for application. See Section 3.8.
- Breathing air:** provide Grade D air source for blast operators. See Section 3.9.
- PPE:** provide all the necessary personal protective equipment. See Section 3.10.
- Pressure relief valve:** install relief valve if not provided on air compressor. See Section 3.11 for information on pressure relief valve installation.
- Blast nozzle:** select size based on available cfm noted above. See Section 5.13.
- Blast hose:** select size three times the nozzle size to be used. See Section 5.12.
- Injection Module:** full port threaded coupling installed on outlet. See Section 5.24.
- Adjust abrasive spider:** adjust height per drawing in Section 9.12 (spider is optional).
- Operator training:** all operators must completely read and understand the operation and maintenance manual and be properly trained in equipment and blast operations.
- Abrasive blaster setup:** follow procedures in Section 6.0.

## 4.0 Abrasive Blast System General Operation

The function of the Schmidt® AmphiBlast™ is to provide a mixture of wet abrasive and compressed air to a blast nozzle. The abrasive blast stream through the blast nozzle is used for removing rust, paint, or other unwanted surface defects. After abrasive blasting, the surface is washed off and blown dry before it is ready for new paint or coating.

An abrasive blaster is one of a group of components used in an abrasive blasting job. The typical components are an air compressor, moisture removal device, an abrasive blaster, blast hose, a blast nozzle, operator personal protective equipment, and blast abrasive. See Figure 4.1.

The blast abrasive is loaded into the abrasive blaster through the abrasive inlet at the top of the blaster. All the compressed air must be removed from inside the abrasive blaster before it can be filled with abrasive. The abrasive can be bag loaded, or loaded from a Schmidt storage hopper. To begin blasting, the abrasive inlet is closed and the abrasive blaster is filled with compressed air from the air compressor. Since moisture creates problems in the blast operation, it is common for the compressed air to be fed through a moisture removal device, such as a Schmidt AirPrep System. The air pressure in the abrasive blast vessel is equal to the air pressure in the blast hose where it connects at the metering valve. This equal pressure is needed to allow the blast abrasive to flow downward by gravity. The abrasive flow is controlled by the metering valve at the bottom of the blaster. From the metering valve the blast abrasive flows into the blast air stream where it is injected with water. The mixture of wet abrasive and air then flow through the blast hose. The speed of blast air and wet abrasive mixture is greatly increased by the blast nozzle onto the work surface. The high speed of the air and abrasive is what gives it the energy to blast rust and paint off of surfaces. Even though wet blasting greatly reduces the amount of dust produced during blasting, there can still be a small amount of dust that is harmful; therefore, all blast operators must use personal protective equipment during the blast operation.

All the components required for the blast operation (except for the air compressor) are available from Axxiom Manufacturing, Inc. Call Axxiom to locate a distributor.

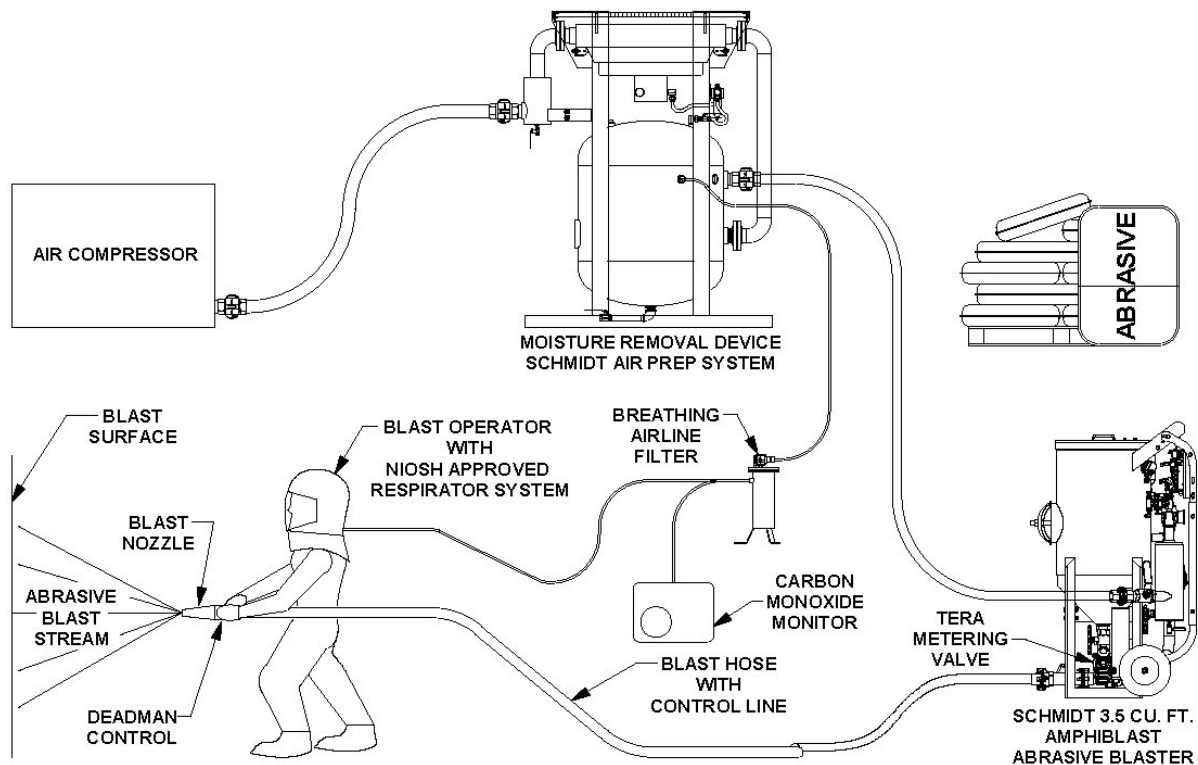

**Figure 4.1 – Typical Abrasive Blast System**

## 5.0 AmphiBlast™ General Operation

See Figure 5.1 to help understand the general operation of an AmphiBlast™ abrasive blaster. Do not attempt to operate the AmphiBlast before reading all sections of this manual and following all setup procedures. Read Sections 5.1 through 5.25 for a detailed explanation of all components of the AmphiBlast.

The AmphiBlast abrasive blaster is a *pressurized system*; meaning the blaster remains pressurized when the deadman lever (#12) is released.

The AmphiBlast abrasive blaster (#1) will pressurize when the blowdown ball valve (#4) is closed and the air inlet ball valve (#3) is opened. The compressed air flows through the moisture separator (#7) to the blast outlet piping and into the abrasive blast vessel (#1). The air flow into the blast vessel internal piping will push the pop-up (#5) against the popup gasket (#6). This will seal the abrasive inlet which allows the air flow to fill and pressurize the abrasive blast vessel (#1).

Blasting starts when the deadman lever (#12) is pressed down which will pneumatically or electrically open the blast control valve (#20). When the control valve opens, it sends an air signal that simultaneously opens the automatic air valve (#9), the Tera Valve™ (#14) and the water control valve (#52). Compressed air will pressurize the blast hose (#10) when the automatic air valve (#9) is opened. At the same time, the Tera Valve (#14) and water control valve (#52) will open allowing abrasive to fall through and water to be injected into the blast air stream. The abrasive flow can be increased or decreased by turning the knob on top of the Tera Valve (#14).

Blasting stops when the deadman lever (#12) is released. This will close the blast control valve (#20) and vent the air signal to the automatic air valve (#9), Tera Valve (#14) and water control valve (#52). When the signal air vents, all of the valves spring return into their “normally closed” position. The abrasive blaster (#1) remains pressurized when the automatic air valve (#9), Tera Valve (#14) and water control valve (#52) are closed.

The abrasive blaster (#1) is depressurized by closing the air inlet ball valve (#3) and then opening the blowdown ball valve (#4) to completely vent the compressed air.

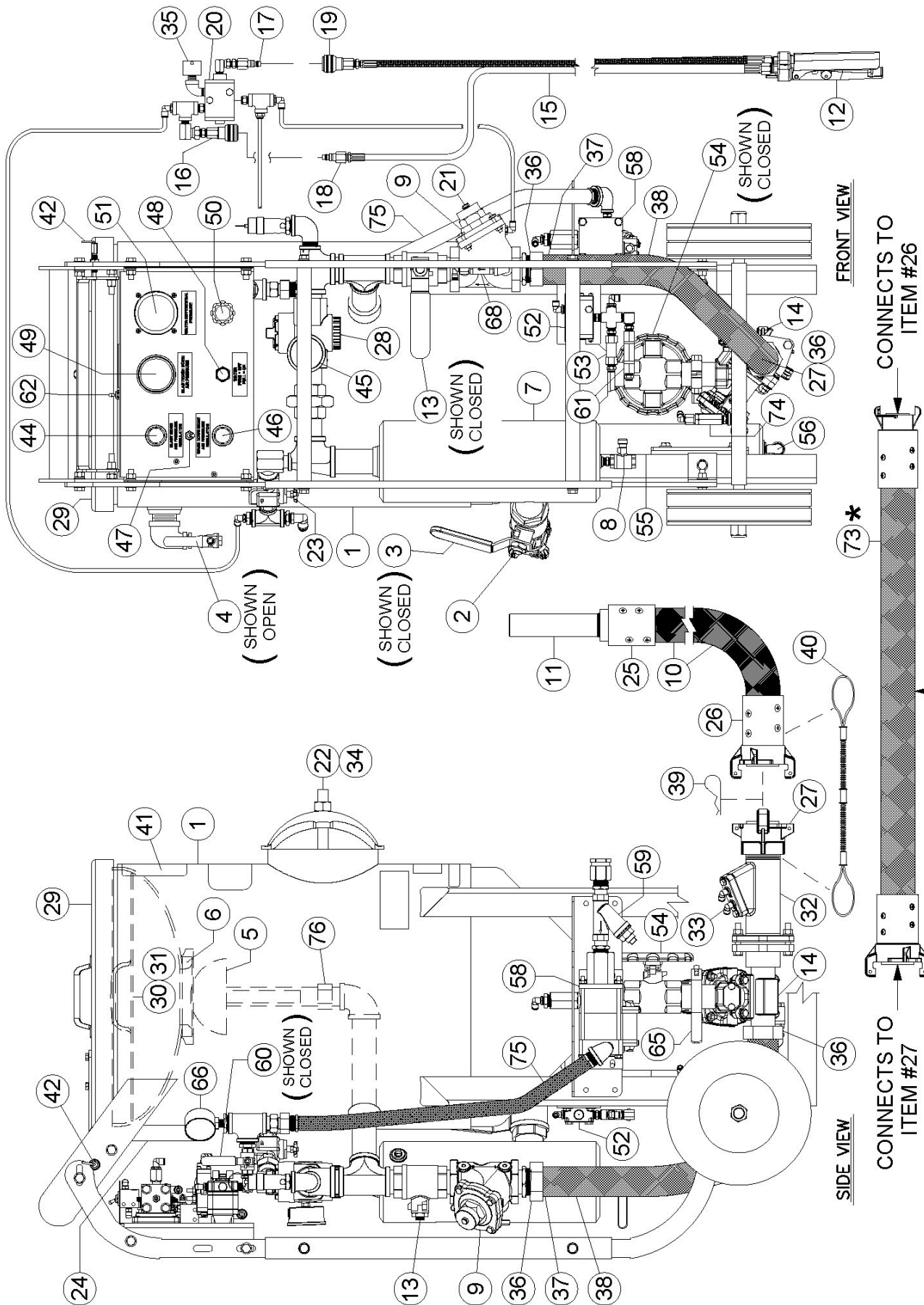

**\*NOTE:** ADD 1-1/2" x 36" LG. ADAPTER HOSE (#10) BETWEEN INJECTION MODULE (#32) AND BLAST HOSE (#73) IF BLAST HOSE COUPLING (#26) IS NOT FULL PORT (SEE SECTIONS 5.12 AND 5.24)

**Figure 5.1 – AmphiBlast™ With Pneumatic Blast Controls**

## 5.1 Popup Valve (abrasive inlet)

The blaster is filled with abrasive through the abrasive inlet at the top of the pressure vessel (#1). The abrasive inlet is automatically sealed by the popup head (#5) when the blaster is pressurized. The air flow into the internal piping pushes the popup head (#5) up against the gasket (#6). See Figure 5.2.

### **⚠ WARNING**

Pinch point hazard. Vessel pressurization will close the popup. Keep fingers clear of the popup opening. Disconnect air supply prior to performing popup maintenance.

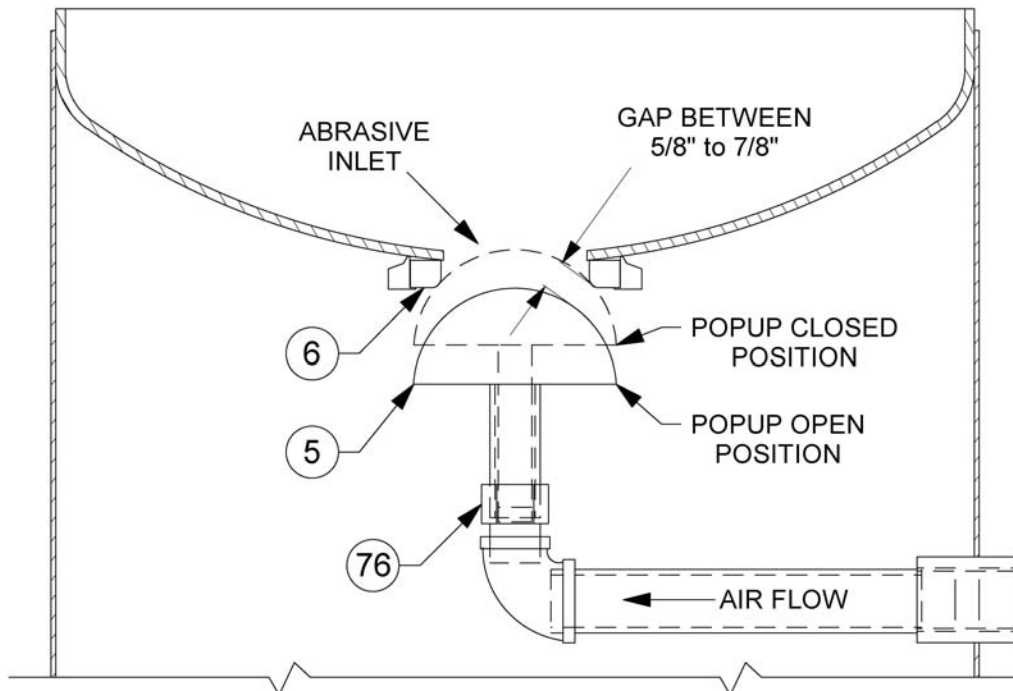

Figure 5.2 – Standard Popup Assembly & Internal Piping

## 5.2 Air Supply Connection

Air is supplied to the abrasive blaster through a hose connection at the air inlet crowfoot (#2). The air supply hose connected to the abrasive blaster must be the same diameter as the air supply piping and rated at a minimum of 150 psi operating pressure. See the drawings and parts lists in Section 9.0 and refer to Sections 3.4 and 5.14.

## 5.3 Air Inlet Ball Valve (pressurize)

The air inlet ball valve (#3) is used to turn on and turn off the air flow to the abrasive blaster. When the inlet ball valve is opened, air will flow through the moisture separator (#7) and into the blast vessel internal piping. The air flow will automatically close the popup valve at the abrasive inlet and pressurize the abrasive blaster (see Figure 5.2). The blowdown ball valve (#4) must be closed before opening the air inlet ball valve (#3).

**Note:** The abrasive blaster will automatically pressurize when the air inlet ball valve (#3) is opened. The blaster must be manually depressurized thereafter. See Sections 5.5 and 6.2.

### **⚠ DANGER**

The AmphiBlast™ is a pressurized vessel. Propelled objects will cause serious injury or death. Read and follow all pre-operation and operating procedures prior to pressurizing the abrasive blaster. See Sections 6.0 and 7.0.

## 5.4 Moisture Separator (optional)

The air inlet moisture separator (#7) is a standard option on the AmphiBlast™. Air flow into the blaster passes through the moisture separator (#7) which removes moisture, oil and dirt particles from the inlet air. The water that is removed by the separator is drained by opening the ball valve (#8) at the bottom of the separator. This ball valve should be left slightly opened anytime the blaster is in operation. This allows water to be drained as it is filtered from the blast air.

## 5.5 Blowdown Ball Valve (depressurize)

The blowdown ball valve (#4) is used to release all the compressed air (depressurize) from inside the abrasive blaster. The abrasive blaster must be depressurized before filling with abrasive or before performing any maintenance. The air inlet ball valve (#3) must be closed before depressurizing the abrasive blaster.

**Note:** The AmphiBlast abrasive blaster will automatically pressurize when the air inlet ball valve (#3) is opened. The blaster must be manually depressurized thereafter. See Sections 5.3 and 6.2.



Airborne particles and loud noise hazards from blowdown exhaust air can cause serious injury and loss of hearing. Wear approved eye and ear protection. Stay clear of blowdown air path. DO NOT place hands or other body parts in the blowdown air path. Make sure no personnel are in the blowdown air path.

## 5.6 Choke Valve

The choke valve (#13) is used to clear any trash that may get into the blast vessel and block the Tera Valve™ orifice. Whenever trash (paint chips, cigarette butts, etc.) blocks the Tera Valve orifice the procedure is to fully open the Tera Valve by backing out the knob, then press down the deadman lever (#12) to begin blasting. While blasting, have an assistant close the choke valve (#13) completely for about one second. This creates differential pressure at the Tera Valve (high pressure above; low pressure below). The higher pressure from the blast vessel should be enough to force the trash through the Tera Valve orifice. Keep the choke valve (#13) fully open at all other times while blasting to minimize excess Tera Valve (#14) wear. **Note:** Set the abrasive cutoff valve/switch (#62) to the on-position for the choke procedure. See Section 5.11.



Do not aim blast nozzle towards yourself or any person. System malfunction can cause accidental start up and result in injury to personnel.

A secondary purpose of the choke valve is as a manual shut off valve for the blast air supply. When the choke valve (#13) is closed it will shut off the blast air supply to the blast outlet.

## 5.7 Automatic Air Valve (blast air valve)

The automatic air valve (#9) is a normally closed valve that opens to supply blast air to the blast hose (#10) and blast nozzle (#11). The automatic air valve (#9) opens when it receives air to its signal port. This happens when the deadman lever (#12) is pressed down which opens the blast control valve (#20) sending an air signal to the automatic air valve. When the deadman lever is released, the air signal from the blast control valve vents and the automatic air valve spring closes to stop blast air flow to the blast hose and nozzle. See Section 9.5.



## 5.8 Tera Valve™ (abrasive metering valve)

The Tera Valve (#14) is a normally closed valve that opens to supply abrasive into the blast air stream. The Tera Valve opens when it receives air to its signal port (see Section 9.4). This happens when the deadman lever (#12) is pressed down which opens the blast control valve (#20) sending an air signal to the Tera Valve. When the deadman lever is released the air signal from the blast control valve vents and Tera Valve spring closes to stop abrasive flow to the blast hose (#10) and nozzle (#11).

The Tera Valve also controls (meters) abrasive flow by use of an adjustable orifice. The amount this orifice opens is controlled by turning the knob at the top of the Tera Valve. The knob sets the stopping point of the plunger (See Section 9.4). Turning the knob clockwise reduces the orifice size which decreases abrasive flow. Turning the knob counter-clockwise increases the orifice size which will increase the abrasive flow to the blast nozzle. The Tera Valve cap has a VPI® decal on the side to use as reference as to the amount the orifice is open. Adjustments to the abrasive flow should be made by turning the knob a little at a time. Test the adjustment by starting the blast for a short period to determine if further adjustment is needed.

A diverter plate and gasket must be added to a Tera Valve (#14) used on an AmphiBlast™ system. The diverter plate must be oriented properly to work correctly. See Section 9.4 for diverter plate location and orientation.

The Tera Valve has a flanged cleanout used to purge trash that blocks abrasive flow. This is done by removing the clean out plug and pressing down the deadman lever (#12). The blast air flow purges trash through the clean out valve. The plug must be replaced after purging and the two retaining bolts securely tightened to 7 ft.lb.



Airborne particles and loud noise hazards from purge air can cause serious injury and loss of hearing. Wear approved eye and ear protection. Stay clear of purge air path. DO NOT place hands or other body parts in the purge air path. Make sure no personnel are in purge air path.

## 5.9 Deadman Valve/Switch (blast control)

The deadman valve/switch is part of a system that controls the blast operation. The deadman valve/switch (#12) allows the operator to remotely start and stop the blast operation. The deadman is mounted at the end of the blast hose assembly (#10) close to the blast nozzle (#11) to give the operator easy control of the blast operation.

The Deadman is either a pneumatic valve or an electric switch depending on the type of abrasive blaster control system. When the deadman lever is pressed down it sends either a pneumatic or electric signal to the blast control valve (#20). The control valve opens and sends an air signal to the automatic air valve (#9), the water shut off valve (#52) and the Tera Valve (#14). See Sections 9.1, 9.2, 9.6, 9.8, and 9.9.

## 5.11 Abrasive Cutoff

There are three uses for the abrasive cutoff feature. The first is to allow blasting air and water without abrasive (wash down). This is useful for washing off abrasive from an item that has been wet blasted. See Section 7.7 for instructions on the wash down procedure.

The second is to allow blasting air without water and abrasive (blow off). This is useful for blowing off abrasive from an item that has been dry blasted or drying off an item after it has been washed down. See Section 7.8 for instructions on the blow off procedure.

The third use is to purge abrasive out of a blast hose. This minimized the chance of abrasive collecting in the blast hose when the blast operation has stopped. The abrasive at rest in the blast hose can cause surges when restarting the blast operation. To purge the hose after blasting, turn the abrasive cutoff valve/switch (#62) to the “OFF” position and continue blasting until abrasive no longer comes out of the blast nozzle (#11).

## 5.12 Blast Hose

The blast air, water and abrasive mixture flows from the Tera Valve™ (#14) to the blast nozzle (#11) through the blast hose assembly (#10). The typical length of the blast hose is 50ft; however blast hose extensions can be added to increase length. For higher efficiency keep the blast hose as short as possible. Increased blast hose length causes pressure drop at the blast nozzle which reduces the blast efficiency. For higher efficiency use a blast hose with an inside diameter that is approximately three times the nozzle throat diameter. Keep the blast hose as straight as possible. Sharp bends create high wear points. Static electricity is generated by the abrasive flow through the blast hose. To minimize chance of static electrical shock to operating personnel only use anti-static blast hose, properly electrically bond the blast nozzle, blast hose couplings, and the equipment, and properly install a earth ground to the abrasive blaster.



Static electric shock hazard. To minimize chance of static electrical shock to operating personnel only use anti-static blast hose, properly electrically bond the blast nozzle, blast hose couplings, and the equipment, and properly install a earth ground to the abrasive blaster.

**CRITICAL:** To function properly, a full port threaded coupling (#27) is required on the outlet of the injection module (#32). If the blast hose assembly (#10) being used does not have a full port hose coupling (#26), install the provided 1-1/2" x 3' lg. adapter hose (#73) between the full port threaded coupling (#27) and the blast hose assembly (#10).

**Note:** To reduce operator fatigue a blast whip hose can be used along with the blast hose. A whip hose is thinner wall and lighter weight hose. Consult an Authorized Schmidt® distributor.

## 5.13 Blast Nozzle

The blast nozzle (#11) is an important part of the blast operation since the size of it determines the air flow and abrasive requirement. The amount of air flow and abrasive determine how quick blasting can be done. The larger the nozzle, the more air and abrasive will be needed. The larger the nozzle size the greater the blast productivity. However, for a fixed amount of air supply, increasing the nozzle size will reduce the blast pressure. For best performance the blast pressure must be maintained as high as possible. Therefore, select the nozzle size based on the amount of air available and then adjust the abrasive flow at the Tera Valve (#14) as needed.

The nozzle size is indicated by a small number on the outside. This number represents the nozzle throat diameter in sixteenths of an inch; for example, a #5 nozzle has a throat diameter of 5/16". See the tables in Section 13.0 for approximate air and abrasive consumption for each nozzle. **Note:** For the best possible mixture of air to abrasive, the blast hose and piping must be at least three times the size of the blast nozzle.

## 5.14 Hose Connection

All air hose, blast hose, and threaded couplings have two pin holes that align when connected. To protect against accidental hose disconnections, safety pins must be installed through these holes. As a secondary safety measure each hose connection should also include a hose whip check that will hold the hose if there is an accidental disconnection. Connect one loop to each side of the connection and stretch out as shown in Figure 5.4 below. All air hose, blast hose, and threaded couplings have a gasket that seals the connection and should be replaced when air is leaking.



Failure to install safety pins on all air and blast hose couplings can result in hose disconnects and could result in serious injury or death.

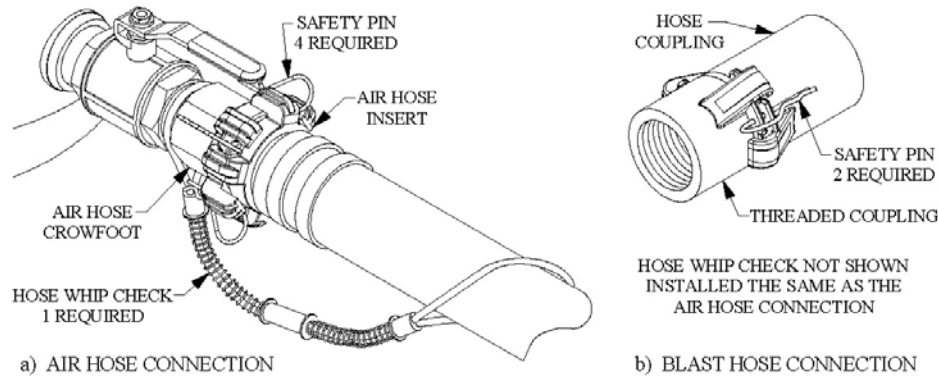

**Figure 5.4 – Hose Connection Disconnect Protection**

## 5.15 Abrasive Shut-Off Valve

The abrasive shut-off valve (#54) is used to block the abrasive flow to the Tera Valve™ (#14). This allows the user to remove the Tera Valve from the blast vessel without emptying the abrasive. Turn the abrasive shut-off valve handle to the horizontal position to block abrasive flow. The spring clamp (#65) can then be removed to separate the Tera Valve from blast vessel (#1). See Figure 5.5.



The Abrasive blaster is a Pressurized Vessel. Propelled objects will cause serious injury or death. Depressurize vessel before performing any maintenance. See Section 6.2.

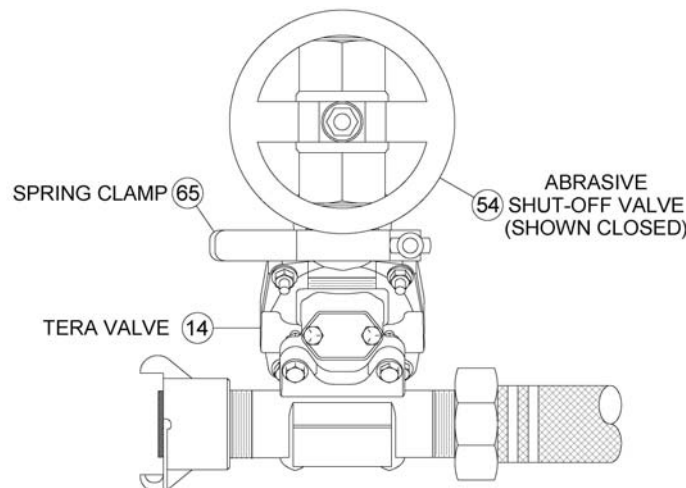

**Figure 5.5 – Abrasive Shut-Off Valve**

## 5.16 Mode Selector

The mode selector (#47) allows you to quickly switch back and forth between blast pressure and washdown pressure without having to adjust the pressure settings. Move the mode selector (#47) to the up position for blasting. Move the mode selector (#47) to the down position for wash down.

## 5.17 Blast Pressure Regulator

To blast objects that are fragile it is necessary to reduce the blast air pressure. The blast pressure regulator (#44) is used to adjust the blast pressure while in “BLAST MODE”. The blast pressure is shown by the blast/wash down air pressure gauge (#49). The adjustment must be made while blasting so the effects are visible. To adjust the blast pressure, pull the regulator knob out to unlock it. Turn the knob clockwise to increase pressure and counter clockwise to decrease pressure. When the desired pressure is reached, push the knob in to lock it and protect against accidental changes.

## 5.18 Washdown Pressure Regulator

The wash down pressure regulator (#46) is used to adjust the blast pressure while in “WASH DOWN MODE”. The wash down pressure is shown by the blast/wash down air pressure gauge (#49). The adjustment must be made while blasting so the effects are visible. To adjust the wash down pressure, pull the regulator knob out to unlock it. Turn the knob clockwise to increase pressure and counter clockwise to decrease pressure. When the desired pressure is reached, push the knob in to lock it and protect against accidental changes. The recommended starting wash down pressure is 50 psi, then make adjustments to achieve the desired results.

## 5.19 Inlet Pressure Gauge

The inlet pressure gauge (#45) shows the air pressure supplied by the air compressor. This gauge makes it possible to easily troubleshoot an insufficient air supply. If the pressure on the inlet pressure gauge (#45) drops while blasting, then the air supply is insufficient for the nozzle size and blast pressure combination being used. Refer to Section 3.3 for air requirements. Fluctuations in the blast pressure will make it impossible to maintain consistent water differential pressure. There are three ways to correct the problem, 1) change to a larger air compressor, 2) change to a smaller nozzle or 3) reduce the blast pressure until no pressure drop is observed on the inlet pressure gauge (#45). See Section 7.4 for procedure.

## 5.20 Water Pump

The water pump (#58) uses compressed air to create a pressurized water source that is injected into the blast stream as it passes through the injection module (#32). The water pressure is controlled by the water differential pressure regulator (#50).

**CRITICAL:** The water pump (#58) must be primed the first time the unit is used or if the water supply drops below the water outlet coupling on the water tank (optional). Do not run the water pump (#58) if the water level falls below the water tank outlet to the water pump. Running the water pump (#58) dry will cause damage to the water pump. Refer to water pump manufacturer’s manual for more information. See Section 7.3 for the water pump priming procedure. The water pump does not require lubrication.



In cold weather water must be drained from the water pump to avoid freezing which can cause costly damage. Turn off the water supply and open the water pump priming ball valve (#56) to drain the water.

## 5.21 Water Differential Pressure Regulator

The water differential pressure regulator (#50) allows you to adjust the water pressure in relationship to the blast pressure. **Note:** The water pressure always needs to be higher than the blast pressure. The difference in pressure can be seen on the water differential pressure gauge (#51). The adjustment must be made while blasting so the effects are visible. To adjust the water differential pressure, turn the knob clockwise to increase pressure and counter clockwise to decrease pressure. It is recommended to start at 10 psi of differential pressure and then fine-tune to achieve the desired results.

## 5.22 Water On/Off Palm Button Control Valve

The water on/off palm button control valve (#48) is used to change between wet blast and dry blast. Pull the palm button out (“ON” position) for wet blast and push the palm button in (“OFF” position) for dry blast. When the water on/off palm button control valve (#48) is in the “OFF” position, it stops the air signal to the water control valve (#52) preventing the water from turning on. See drawing in Section 9.13.



Wet blasting greatly reduces air borne dust but the use of a respirator is still required during blast operation. All operators and personnel in the vicinity must wear OSHA approved respiratory protection during the operation of this equipment See Sections 3.9, 3.10, and OSHA 29 CFR 1910.134

## 5.23 Water Control Valve

The water control valve (#52) is a normally closed valve that opens to inject water into the blast stream. The water control valve (#52) opens when it receives air to its signal port. This happens when the deadman lever (#12) is pressed down which opens the blast control valve (#20) sending an air signal to the water control valve (#52). When the deadman lever is released, the air signal from the blast control valve (#20) vents and the water control valve (#52) spring closes to stop the flow of water. See drawing in Section 9.7.

## 5.24 Injection Module

The injection module (#32) is where water is introduced into the blast stream. The injection module holds the spray nozzle (#33) in the optimum position to wet the abrasive in the blast stream as it exits the Tera Valve™ (#14).

**CRITICAL:** The injection module (#32) must be orientated correctly to work properly. See drawings in Section 9.10.

**CRITICAL:** To function properly, a full port threaded coupling (#27) is required on the outlet of the injection module (#32). If the blast hose assembly (#10) being used does not have a full port hose coupling (#26), install the provided 1-1/2” x 3’ lg. adapter hose (#73) between the full port threaded coupling (#27) and the blast hose assembly (#10).

## 5.25 Blaster Options and Accessories

There are many options, accessories, and field conversion kits available to upgrade Schmidt® abrasive blasters. Options include the abrasive spider, blast hour meter, “Short Stop” blast system, and others. Some of the options are discussed below. For further information visit the Axxiom website or consult Axxiom Manufacturing or an Authorized Schmidt® distributor.

### 5.25.1. Abrasive spider

The abrasive spider is a device that is mounted in the top head of the abrasive blaster. The spider is added to blasters that will be installed below an abrasive storage hopper. The spider creates a void area above the blaster abrasive inlet keeping the abrasive from sitting on top of the popup. Abrasive piled on top of the popup restricts movement and can prevent the popup from properly sealing. A leaking popup will cause abrasive flow problems and wear to the popup and popup gasket. The spider is typically installed at the time of manufacture; however, drop-in spiders are available for field installation. Refer to the drawing in Section 9.12.

### 5.25.2. Water Tank

The Amphiblast Lite comes standard with a 3/4” water hose connection. However, if a water source is not readily available, an optional 15 gallon water tank can be mounted to the vessel. See Figure 5.6. For instructions on filling the water tank refer to Section 7.2. See Section 9.14 for installation and parts list for water tank.

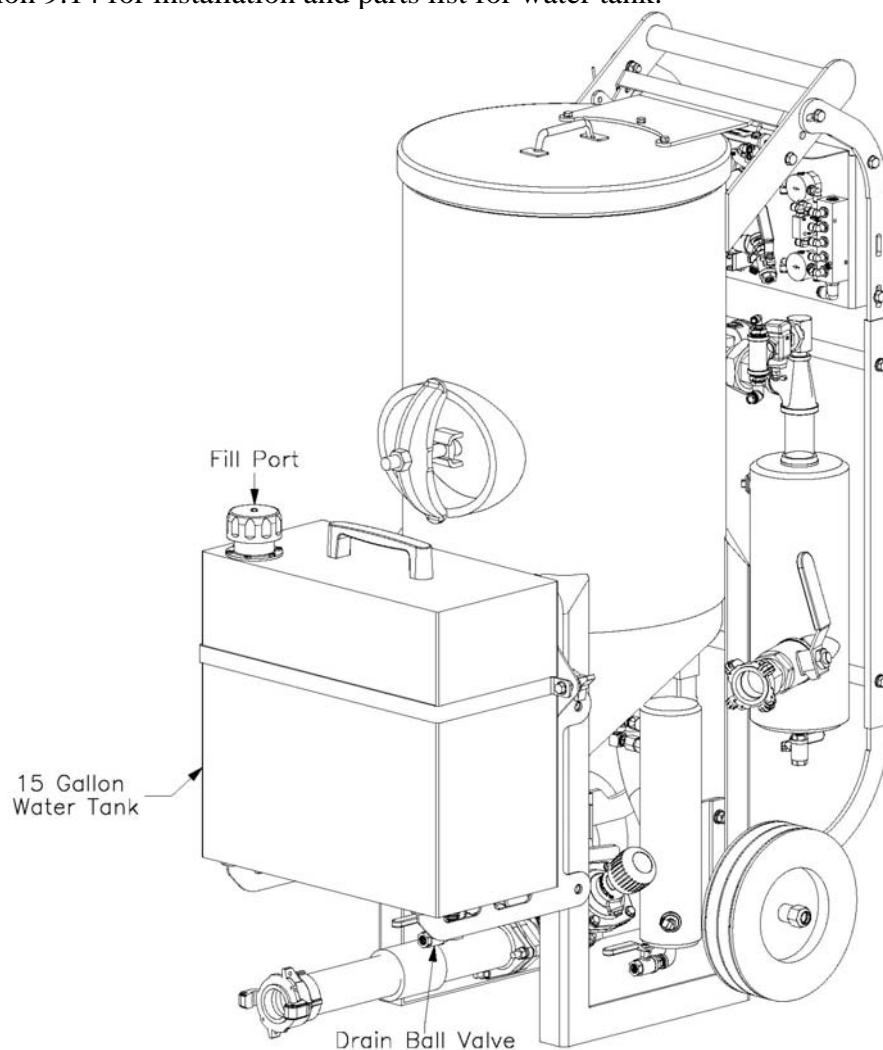

**Figure 5.6 – Amphiblast™ Lite with Optional Water Tank**

## 6.0 Pre-operation Procedures

### DANGER

Failure to follow the procedures below could result in serious injury or death. In addition to these procedures completely read and understand all sections of this *Abrasive Blaster Operation and Maintenance Manual*.

### DANGER

Explosion Hazard. Do Not operate the AmphiBlast Abrasive Blast system in confined spaces without proper ventilation. Airborne substances that make up the items and substrates being blasted can be ignitable when mixed with airborne dust from the blast abrasive. Consult plant authorities.

### DANGER

The Abrasive Blaster is a pressurized vessel. Propelled objects will cause serious injury or death. Depressurize vessel before performing any maintenance. See Section 6.2.

### 6.1 Abrasive Blaster Setup Procedure (see Figure 6.2)

- 6.1.1. Confirm that the abrasive blaster is properly maintained and inspected as detailed in Section 8.0.
- 6.1.2. Static electricity is generated by the abrasive flow through the blast hose. To minimize chance of static electrical shock to operating personnel only use anti-static blast hose, properly electrically bond the blast nozzle, blast hose couplings, and the equipment, and properly install a earth ground to the abrasive blaster. See Section 5.12.

### CAUTION

Static electric shock hazard. To minimize chance of static electrical shock to operating personnel only use anti-static blast hose, properly electrically bond the blast nozzle, blast hose couplings, and the equipment, and properly install a earth ground to the abrasive blaster. See Section 5.12.

- 6.1.3. To mitigate risk of dust explosion avoid blasting in confined spaces without proper ventilation. Consult plant authorities. See Section 1.20.

### DANGER

Explosion Hazard. Self-Ignition of Dust. Do Not operate the AmphiBlast Abrasive Blast system in confined spaces without proper ventilation. Consult plant authorities. See Section 1.20.

- 6.1.4. Do Not operate this equipment without a pressure relief device in place. The ASME Code requires that all vessels be provided with pressure relief devices. See Section 3.11.

### DANGER

Rupture Hazard. Operating the pressure vessel above the maximum allowable working pressure can result in rupturing the pressure vessel. Install an air pressure relief valve to protect against over pressurization of the blast vessel. See Section 3.11.

- 6.1.5. Make certain that the abrasive blaster is not pressurized. Follow the depressurizing procedure given in Section 6.2.

### WARNING

Airborne particles and loud noise hazards from blowdown exhaust air can cause serious injury and loss of hearing. Wear approved eye and ear protection. Stay clear of blowdown air path. DO NOT place hands or other body parts in the blowdown air path. Make sure no personnel are in the blowdown air path.

- 6.1.6. Properly install the handway cover (#22) and gasket (#34). See Section 6.4.

- 6.1.7. Verify that all required personal protective equipment is available for each operator and in good operating condition (safety glasses, safety shoes, ear plugs, gloves, airline filter, respirator, & carbon monoxide monitor). *Critical: Adhere to all local, state, and federal regulations including, but not limited to, OSHA (Occupational Health and Safety Administration). Pay close attention to requirements regarding breathing air quality. When an oil-lubricated air compressor is used, additional requirements for a high temperature alarm and/or a carbon monoxide monitor become necessary. See Sections 3.9 and 3.10.*

**⚠ WARNING**

Failure to use personal protective equipment could result in serious injury or death.

- 6.1.8. Hose clamp the deadman (#12) to the blast hose assembly (#10) in a comfortable position behind the nozzle holder (#25).
- 6.1.9. Wire tie the twinline hose (#15) or electric deadman extension cords to the blast hose assembly (#10).
- 6.1.10. Screw nozzle (#11) into the nozzle holder (#25) at end of the blast hose assembly (#10).
- 6.1.11. Connect the blast hose coupling (#26) to the threaded coupling (#27) on the injection module (#32). Then install safety pins (#39) and a hose whip check (#40) to protect against accidental disconnections during operation. See Sections 5.14 and 8.7.

**⚠ WARNING**

Failure to install safety pins on all blast hose couplings can result in hose disconnects and could result in serious injury or death. See Sections 5.14 and 8.7.

- 6.1.12. Connect the twinline hose quick disconnects or the electric deadman extension cord to the mating disconnects on the abrasive blaster #18 to #16 and #19 to #17. See Section 9.1 for pneumatic and 9.2 for electric.
- 6.1.13. Connect a 150 psi rated (minimum) air supply hose to the air inlet crowfoot (#2) and install safety pins (#39) and a hose whip check (#40) to protect against accidental disconnections during operation. See Sections 5.14 and 8.7.

**⚠ WARNING**

Failure to install safety pins on all air hose couplings can result in hose disconnects and could result in serious injury or death. See Sections 5.14 and 8.7.

- 6.1.14. The following steps apply only to abrasive blasters with electric systems. Connect the electric power cord (#70) to the power-in plug (#17).
- 6.1.15. Connect the electric power cord alligator clips (#70) to the air compressor battery terminals or to another 12Vdc power source. See Figure 6.1.

**⚠ CAUTION**

Electric shock hazard. Abrasive blasters with electric deadman blast control systems must operate on low voltage supply (12-24 volts). To minimize shock hazard, only use low voltage sources and use caution when connecting the power to the abrasive blaster. See Section 3.7.

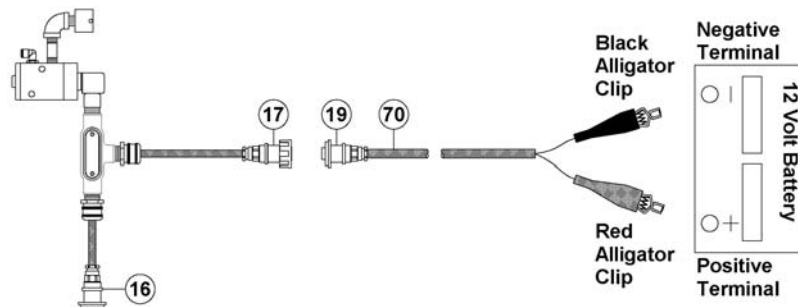

**Figure 6.1 – Electric Power Connection**



## 6.2 AmphiBlast™ Abrasive Blaster Depressurizing Procedure

### ⚠ CAUTION

Do Not leave the abrasive blaster pressurized during long periods of no usage. An undetected air leak can cause costly damage to the pressure vessel at the handway or abrasive inlet.

- 6.2.1. Close the air inlet ball valve (#3). The ball valve is closed when the handle is fully turned to the position shown in Figure 6.2 (handle perpendicular to body). The handle tab will bottom against the ball valve body in the closed position.
- 6.2.2. Slowly open the blowdown ball valve (#4). As the blowdown ball valve (#4) is opened, air pressure inside will exhaust and depressurize the blast vessel (#1).

### ⚠ WARNING

Airborne particles and loud noise hazards from blowdown exhaust air can cause serious injury and loss of hearing. Wear approved eye and ear protection. Stay clear of blowdown air path. DO NOT place hands or other body parts in the blowdown air path. Make sure no personnel are in the blowdown air path.

- 6.2.3. The AmphiBlast abrasive blast vessel (#1) is completely depressurized when the air inlet ball valve (#3) is closed and the blowdown ball valve (#4) is open with no airflow from it. The popup head (#5) will fall open when the blast vessel is completely depressurized.

### ⚠ WARNING

When the popup valve opens after depressurizing, abrasive can be blown out of the blast vessel and into the face and eyes of the operator. Wear OSHA approved safety glasses. See Section 3.10.

- 6.2.4. The blowdown ball valve (#4) should be inspected for proper operation before each use of the abrasive blaster. Confirm that the blowdown ball valve handle turns open and closed without difficulty. See Section 8.0 for inspection and maintenance details.

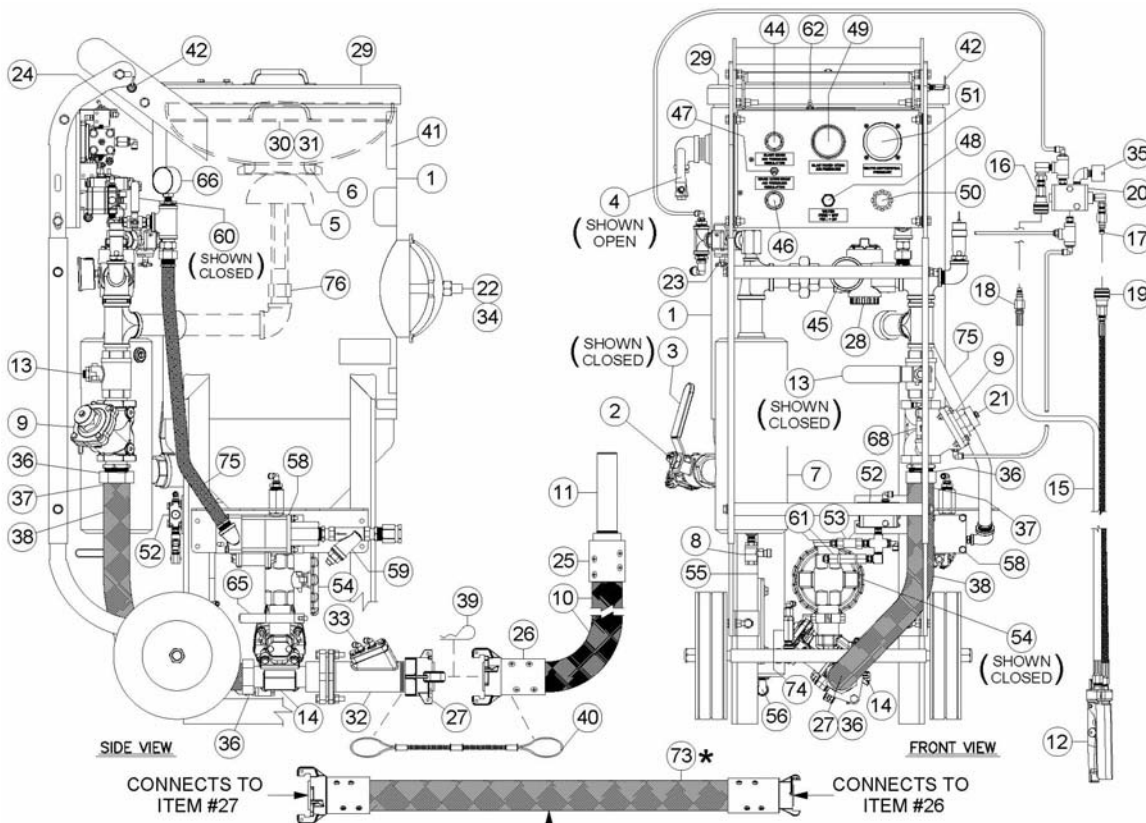

\*NOTE: ADD 1-1/2" x 36" LG. ADAPTER HOSE (#73) BETWEEN INJECTION MODULE (#32) AND BLAST HOSE (#10) IF BLAST HOSE COUPLING (#26) IS NOT FULL PORT (SEE SECTIONS 5.12 AND 5.24)

**Figure 6.2 – AmphiBlast™ With Pneumatic Blast Controls**

## 6.4 Handway Cover Installation Procedures (See Figure 6.4(a))

- 6.4.1. Check that the handway cover, crab, bolt, and gasket are dimensionally correct for the size handway weld ring of the pressure vessel.
  - a) Measure and write down the inside dimensions “A” and “B” of the handway weld ring. See Figure 6.4(a).
  - b) Verify the size of the handway assembly by comparing the weld ring measurements from step “a” to the dimensions shown in Table 6.4(c).
  - c) Verify that the dimensions of the cover, crabs, bolts, and gasket match the corresponding dimensions given in Table 6.4(c). **Note:** The actual dimensions may vary by up to 1/4" from those given in Table 6.4(c).
  - d) Replace any component that is not dimensionally correct. Incorrect dimensions indicate that the component is part of a different size handway assembly.



The handway assembly is part of a Pressurized Vessel. Use of incorrect handway components will result in assembly failure. Assembly failure will propel objects causing serious injury or death.

- 6.4.2. Once a month inspect the handway gasket for tears, cracks, or other wear. Replace if necessary.
- 6.4.3. Once a month inspect the handway weld ring sealing surface inside the vessel. Inspect the handway cover sealing surface. Both surfaces must be smooth.
- 6.4.4. Place the gasket on the handway cover then fit both through the opening.
- 6.4.5. Place the cover and gasket in position against the inside edge of the handway weld ring. Apply a pulling force to hold in position then proceed. **\*See Note below.**
- 6.4.6. Center the gasket on the handway weld ring.
- 6.4.7. Center the handway cover on the gasket.
- 6.4.8. Center the handway crab on the outside weld ring.
- 6.4.9. Slide the handway crab bolt to the inside edge of the slot before tightening. See Figure 6.4(a).
- 6.4.10. When all components are centered and the crab bolt is bottomed in the slot, tighten the nut onto the bolt with a wrench until snug.
- 6.4.11. Only after completing all the pre-operation procedures in Section 6.0 and the abrasive blast vessel is then pressurized, re-tighten the nut with a wrench until snug.
- 6.4.12. Do not over-tighten the crab nut and bolt. Over-tightening could bend the crab out of shape resulting in malfunction of the assembly.
- 6.4.13. Periodically check for leaks.



**\*Note:** Contact Axxiom Manufacturing or an Authorized Schmidt distributor and request information on the new SureFit™ Handway Gasket (patent pending) that eliminates the difficulty of aligning the gasket. Scan the QR Tag on the left to view a short video.

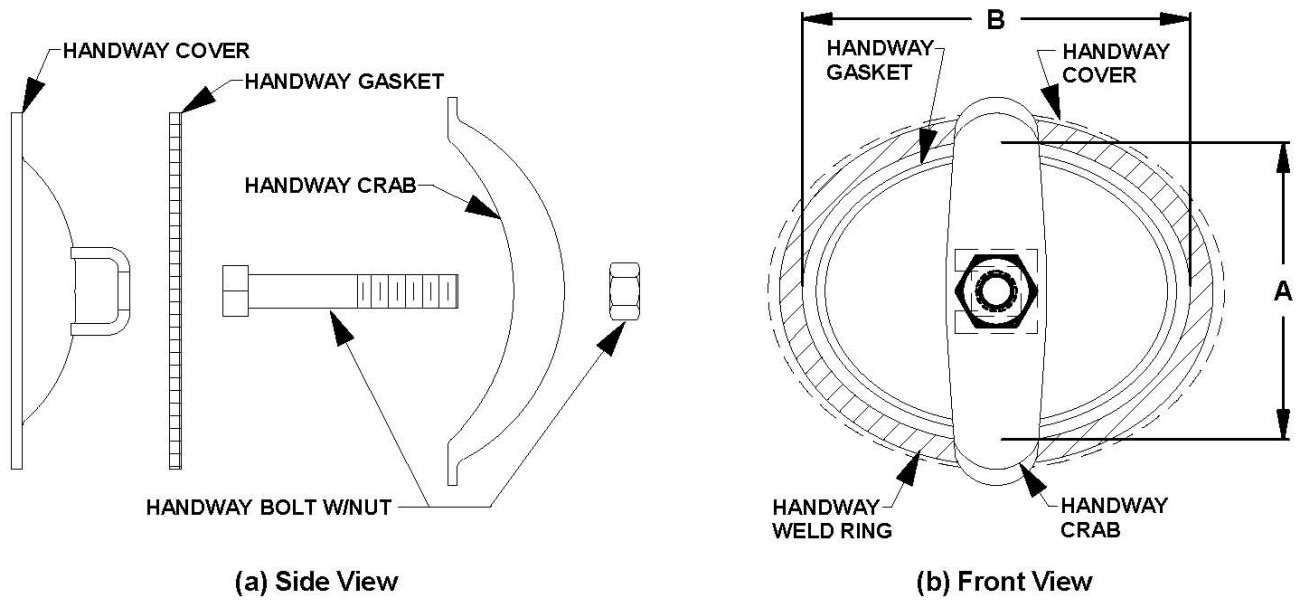

**Figure 6.4(a) – Handway Assembly**

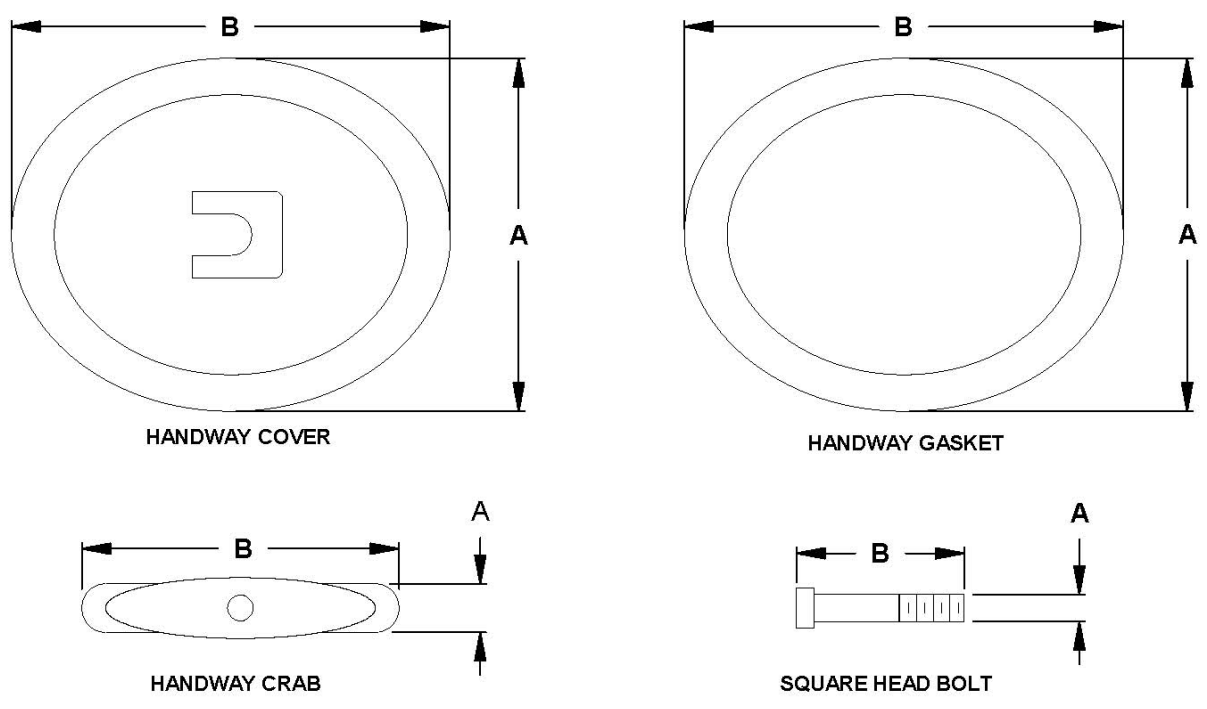

**Figure 6.4(b) – Handway Components**

6" x 8" Handway Dimensions		
Component	A	B
Weld Ring	6-5/8"	8-1/2"
Handway Cover	7-5/8"	9-3/4"
Handway Gasket	7-3/4"	9-3/4"
SureFit™ Gasket	8-1/16"	10-5/16"
Handway Crab	2-3/8"	8-3/4"
Square Head Bolt	3/4"-10 UNC	4-1/2"

**Table 6.4(c) – Handway Component Dimensions**

## 7.0 Operating Instructions

### 7.1 Filling the Abrasive Blaster with Abrasive

- 7.1.1. The Abrasive blaster must be completely depressurized before filling with abrasive. Follow the depressurizing procedure in Section 6.2. Disable the blaster by closing the air inlet ball valve (#3).

#### **WARNING**

Airborne particles and loud noise hazards from blowdown exhaust air can cause serious injury and loss of hearing. Wear approved eye and ear protection. Stay clear of blowdown air path. DO NOT place hands or other body parts in the blowdown air path. Make sure no personnel are in the blowdown air path.

- 7.1.2. Open the vessel lid (#29) and remove the screen (#30) to check that the popup (#5) has dropped open. The open popup indicates that the blast vessel is depressurized. See Figure 7.1. **Note:** The hinged lid (#29) includes a spring loaded retractable plunger (#42) that locks the lid in the open or closed position. This prevents the lid from blowing open during transport or slamming shut when loading the vessel with abrasive.

#### **CAUTION**

Crush and cut hazard. Moving parts can crush and cut. Use the locking pin (#42) to prevent hinged lid from unwantedly opening or closing.

- 7.1.3. Fill the blaster with dry abrasive through the abrasive inlet (#6). Pass recycled abrasive through the screen (#30) to remove trash. Do not over-fill the blast vessel. An excessive amount of abrasive piled above the popup (#5) after the blast vessel is full may prevent the popup from sealing properly.

#### **WARNING**

Pinch point hazard. Vessel pressurization will close the popup. Keep hands and fingers away from popup. Disconnect air supply prior to performing popup maintenance.

- 7.1.4. After completing all the pre-operation procedures in Sections 6.0 and 7.1 pressurize the abrasive blast vessel per Section 7.4, and then check the popup for leaks. Periodically check the popup for leaks thereafter.

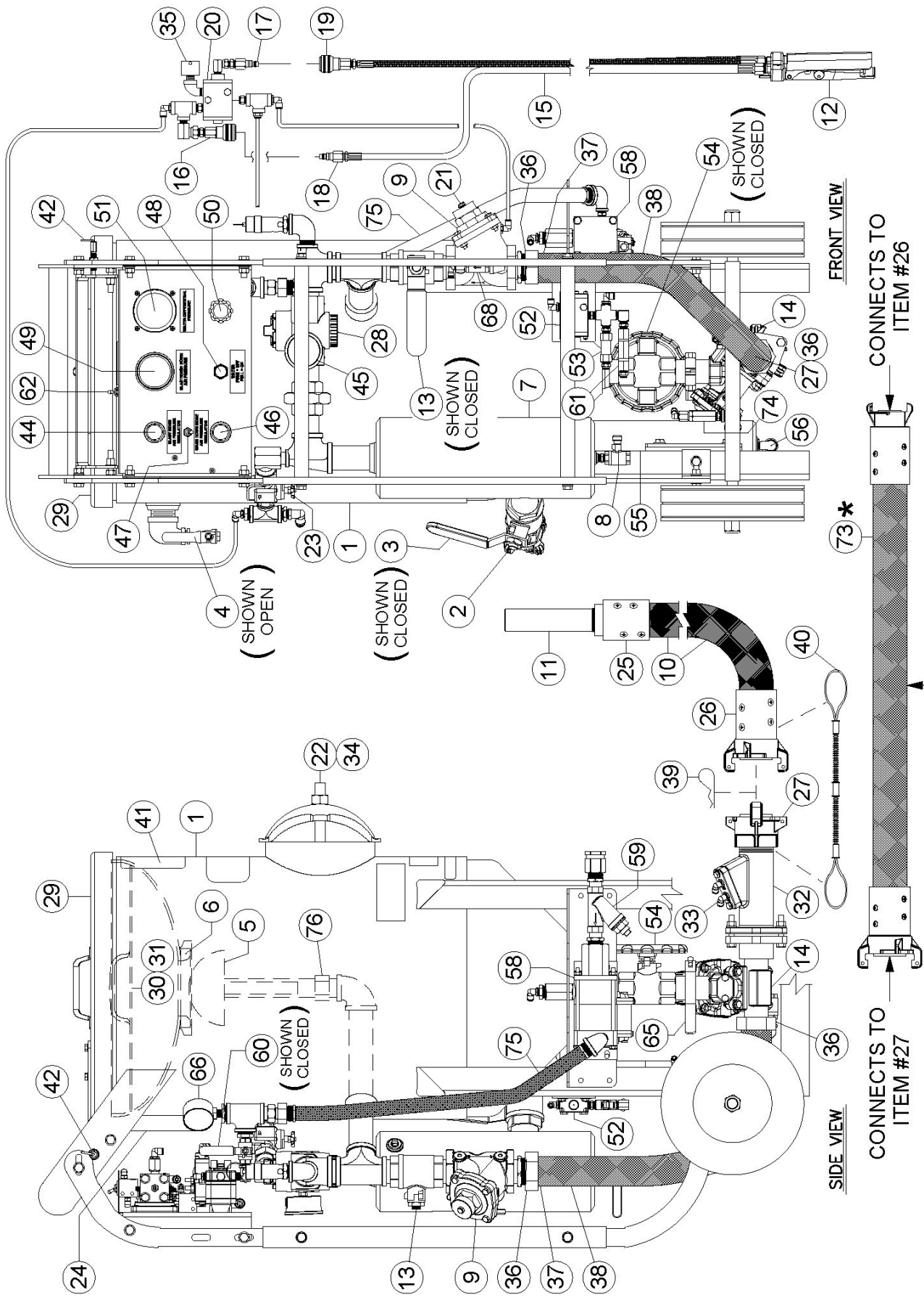

**\*NOTE:** ADD 1-1/2" x 36" LG. ADAPTER HOSE (#73) BETWEEN INJECTION MODULE (#32) AND BLAST HOSE (#10) IF BLAST HOSE COUPLING (#26) IS NOT FULL PORT (SEE SECTIONS 5.12 AND 5.24)

**Figure 7.1 – AmphiBlast™ With Pneumatic Blast Controls**

## 7.2 Filling the Water Tank (Optional. See Section 5.25.2 & Figure 5.6)

- 7.2.1. Attached a water source hose to the garden hose fitting on the water strainer (#59). If so equipped, fill the water tank as detailed below. See Section 5.25.2.
- 7.2.2. Close water tank drain/pressure washer connection port ball valve.
- 7.2.3. Unscrew water tank cap and set to side.
- 7.2.4. Fill water tank with fresh clean water to the desired level.
- 7.2.5. If required, rust inhibitor can be added to the water tank. Follow the instructions from the rust inhibitor manufacturer for the correct amount.
- 7.2.6. Re-install water tank cap.

## 7.3 Priming the Water Pump

- 7.3.1. Make sure to fill the water tank (if so equipped) or confirm water supply is connected and “on” before priming the water pump (#58). See Section 7.2. **CRITICAL:** Running the water pump (#58) dry will cause damage to the water pump.
- 7.3.2. Clean out debris from the water pump strainer (#59). Temporarily close the water tank outlet ball valve to clean the strainer.
- 7.3.3. Open the water tank outlet ball valve.
- 7.3.4. Close the water pump air supply ball valve (#60).
- 7.3.5. Close the blowdown ball valve (#4).
- 7.3.6. Slowly open the air inlet ball valve (#3). This will pressurize the abrasive blaster (#1) and supply air to the controls.
- 7.3.7. Open the water pump priming ball valve (#56). It is located on the bottom of the snubber tank (#55)
- 7.3.8. Turn the knob of the water differential pressure regulator (#50) counter clockwise until the water pump air supply pressure gauge (#66) reads 0 psi.
- 7.3.9. Open the water pump air supply ball valve (#60).
- 7.3.10. Slowly turn the water differential pressure regulator knob (#50) clockwise until the water pump air supply pressure gauge (#66) reaches 25 psi.
- 7.3.11. Close the water pump priming ball valve (#56) after you see a steady stream of water coming out of the ball valve outlet.
- 7.3.12. The water pump (#58) will continue to cycle until the system is pressurized.

## 7.4 Setting the Blast Pressure

- 7.4.1. The abrasive blaster must be properly setup and all operating personnel must be thoroughly trained before beginning the blast operation. All operators must completely read and understand all sections of this manual before beginning the blast operation. See the pre-operation procedures given in Section 6.0.
- 7.4.2. Perform the required inspections and maintenance before beginning the blast operation. See the instructions given in Section 8.0.



The abrasive blaster is a Pressurized Vessel. Propelled objects will cause serious injury or death. Depressurize vessel before performing any maintenance. See Section 6.2.

- 7.4.3. Open the choke valve (#13).
- 7.4.4. Switch the mode selector (#47) to “BLAST MODE”.
- 7.4.5. Turn the water off by pushing in the palm button on the water on/off palm button control valve (#48)
- 7.4.6. Turn the abrasive cutoff valve/switch (#62) to the “OFF” position.
- 7.4.7. Close the blowdown ball valve (#4). The ball valve is closed when the handle is perpendicular to the body (See Figure 7.1).
- 7.4.8. Slowly open the inlet ball valve (#3). This will pressurize the abrasive blaster (#1) and supply air to the deadman controls (#12 & #15).
- 7.4.9. Check the popup, handway, hoses, and piping for leaks while the blaster is pressurized.
- 7.4.10. With one hand, grip the blast hose assembly (#10) and with the other hand press in the deadman (#12) safety button. To begin blasting, aim the blast nozzle at the object to be blasted, then firmly press down the deadman lever (#12). Air will flow into the blast hose and out of the blast nozzle (#11).

**⚠ WARNING**

Do Not aim the blast nozzle towards yourself or any person. A system malfunction or a blocked blast nozzle that clears can trigger accidental start up resulting in injury to personnel.

- 7.4.11. Turn the blast pressure regulator knob (#44) to set the blast/wash down air pressure gauge (#49) to the desired blasting pressure. See Section 5.17 for procedure.
- 7.4.12. Observe the inlet pressure gauge (#45) and blast/wash down air pressure gauge (#49) to make sure the pressure is not dropping.
- 7.4.13. If the pressure is dropping, then slowly lower the blast pressure until the inlet pressure and blast pressure are maintained while blasting. Release deadman lever to stop blasting. If balanced inlet and blast pressure are not achieved at a reasonable level, it may be necessary to obtain a larger air compressor or change to a smaller blast nozzle size (See Section 5.19).

## 7.5 Beginning the Dry Blasting Operation

- 7.5.1. The abrasive blaster must be properly setup and all operating personnel must be thoroughly trained before beginning the blast operation. All operators must completely read and understand all sections of this manual before beginning the blast operation. See the pre-operation procedures given in Section 6.0.
- 7.5.2. Perform the required inspections and maintenance before beginning the blast operation. See the instructions given in Section 8.0.

**⚠ DANGER**

The abrasive blaster is a Pressurized Vessel. Propelled objects will cause serious injury or death. Depressurize vessel before performing any maintenance. See Section 6.2.

- 7.5.3. Open the abrasive shutoff valve (#54).
- 7.5.4. Open the choke valve (#13). Leave the choke valve completely open at all times while blasting. Close the choke valve only for the “choke” procedure (see Section 11.3.2.). Do Not blast for long periods with the choke valve partially closed since this will cause excessive wear in the Tera Valve™ (#14).
- 7.5.5. Switch the mode selector (#47) to “BLAST MODE”.
- 7.5.6. Turn the water off by pushing in the palm button on the water on/off palm button control valve (#48)
- 7.5.7. Turn the abrasive cutoff valve/switch (#62) to the “ON” position.
- 7.5.8. For initial startup, the Tera Valve (#14) should only be partially open. Turn the valve knob clockwise to completely close, then turn counterclockwise about four turns to partially open. The best setting for the valve varies depending on abrasive type, blast pressure, and nozzle size; therefore, it may take more than one adjustment to achieve the desired air/abrasive mixture. Further adjustment can be made later as needed.
- 7.5.9. Close the blowdown ball valve (#4). The ball valve is closed when the handle is perpendicular to the body (See Figure 7.1).
- 7.5.10. Slowly open the inlet ball valve (#3). This will pressurize the abrasive blaster (#1) and supply air to the deadman controls (#12 & #15).
- 7.5.11. Slightly open the ball valve (#8) on bottom of the moisture trap (#7) to permit moisture to continually drain during the blast operation (optional, see Section 5.4). Once each day completely open the drain valve to blow out all moisture and dirt particles.
- 7.5.12. Check the popup, handway, hoses, and piping for leaks while the blaster is pressurized. Periodically check for leaks thereafter.
- 7.5.13. The following steps are for abrasive flow setting which may require several adjustments and testing of the blast flow. It is recommended that testing of the blast be made on a test piece so not to damage anything of value.
- 7.5.14. With one hand grip the blast hose assembly (#10) and with the other hand press in the deadman safety button. To begin blasting, aim the blast nozzle (#11) at the object to be blasted, then firmly press down the deadman lever (#12). Air and blast abrasive will flow into the blast hose and out of the blast nozzle (#11).



Do Not aim the blast nozzle towards yourself or any person. A system malfunction or a blocked blast nozzle that clears can trigger accidental start up resulting in injury to personnel.

- 7.5.15. Turn the blast air pressure regulator knob (#44) to set the blast/wash down air pressure gauge (#49) to the desired blasting pressure. See Section 5.17 for procedure.
- 7.5.16. Observe the blast stream and the coating removal rate. A bluish color in the blast stream indicates a good abrasive to air mixture. Release the deadman lever to stop blasting.



- 7.5.17. If necessary adjust the abrasive flow with the knob on the Tera Valve™ (#14). Turn clockwise for less abrasive flow, or turn counter-clockwise for more abrasive. Due to the length of the blast hose there will be a slight delay in control of the abrasive flow at the nozzle, therefore allow a few seconds before adjusting further.
- 7.5.18. Note the VPI® decal setting on the side of the Tera Valve cap to view the knob position relative to the abrasive flow. The markings relative to the knob can be used as reference when changing nozzle size or abrasive for different applications.
- 7.5.19. Re-test the blast air and abrasive mixture again on a test piece to determine if further adjustment is needed. Release the deadman lever (#12) to stop blasting. Replace screen (#30) and close the lid (#29) to protect against debris from entering blaster vessel.

## 7.6 Beginning the Wet Blasting Operation

- 7.6.1. The abrasive blaster must be properly setup and all operating personnel must be thoroughly trained before beginning the blast operation. All operators must completely read and understand all sections of this manual before beginning the blast operation. See the pre-operation procedures given in Section 6.0.
- 7.6.2. Perform the required inspections and maintenance before beginning the blast operation. See the instructions given in Section 8.0.



The abrasive blaster is a Pressurized Vessel. Propelled objects will cause serious injury or death. Depressurize vessel before performing any maintenance. See Section 6.2.

- 7.6.3. Open the abrasive shutoff valve (#54).
- 7.6.4. Open the choke valve (#13). Leave the choke valve completely open at all times while blasting. Close the choke valve only for the “choke” procedure (see Section 11.3.2.). Do Not blast for long periods with the choke valve partially closed since this will cause excessive wear in the Tera Valve (#14).
- 7.6.5. Switch the mode selector (#47) to “BLAST MODE”.
- 7.6.6. Turn the water “on” by pulling out the palm button on the water on/off palm button control valve (#48).
- 7.6.7. Turn the abrasive cutoff valve/switch (#62) to the “OFF” position.
- 7.6.8. For initial startup the Tera Valve (#14) should only be partially open. Turn the valve knob clockwise to completely close, then turn counterclockwise about four turns to partially open. The best setting for the valve varies depending on abrasive type, blast pressure, and nozzle size; therefore, it may take more than one adjustment to achieve the desired air/abrasive mixture. Further adjustment can be made later as needed.
- 7.6.9. Close the blowdown ball valve (#4). The ball valve is closed when the handle is perpendicular to the body (See Figure 7.1).
- 7.6.10. Slowly open the inlet ball valve (#3). This will pressurize the abrasive blaster (#1) and supply air to the deadman controls (#12 & #15).

- 7.6.11. Slightly open the ball valve (#8) on bottom of the moisture trap (#7) to permit moisture to continually drain during the blast operation (optional, see Section 5.4). Once each day completely open the drain valve to blow out all moisture and dirt particles.
- 7.6.12. Check the popup, handway, hoses, and piping for leaks while the blaster is pressurized. Periodically check for leaks thereafter.
- 7.6.13. The following steps are for setting the water flow and wetting the blast hose (#10). The water differential pressure gauge (#51) setting can only be seen while blasting, so it is easier to perform this adjustment with two people.

**⚠ DANGER**

Wet blasting greatly reduces air borne dust but the use of a respirator is still required during blast operation. All operators and personnel in the vicinity must wear OSHA approved respiratory protection during the operation of this equipment See Sections 3.9, 3.10, and OSHA 29 CFR 1910.134

- 7.6.14. With one hand grip the blast hose assembly (#10) and with the other hand press in the deadman safety button. To begin blasting, aim the blast nozzle (#11) at the object to be blasted, then firmly press down the deadman lever (#12). Air will flow into the blast hose and out of the blast nozzle (#11).

**⚠ WARNING**

Do Not aim the blast nozzle towards yourself or any person. A system malfunction or a blocked blast nozzle that clears can trigger accidental start up resulting in injury to personnel.

- 7.6.15. Turn the blast air pressure regulator knob (#44) to set the blast pressure/wash down air gauge (#49) to the desired blasting pressure. See Section 5.17 for procedure.
- 7.6.16. Adjust the water differential pressure regulator (#50) until the desired water flow is achieved. See Section 5.21 for procedure. It could take approximately 10-15 seconds for the blast hose (#10) to become wetted and for water to reach the blast nozzle (#11). This delay only happens when starting with a dry blast hose (#10). Once the blast hose (#10) has been wetted, the water will reach the blast nozzle (#11) instantly on subsequent start-ups. Release the deadman lever (#12) to stop blasting.
- 7.6.17. Turn the abrasive cutoff valve or switch (#62) to the “ON” position.
- 7.6.18. The following steps are for abrasive flow setting which may require several adjustments and testing of the blast flow. It is recommended that testing of the blast be made on a test piece so not to damage anything of value.1
- 7.6.19. With one hand grip the blast hose assembly (#10) and with the other hand press in the deadman (#12) safety button. To begin blasting, aim the blast nozzle (#11) at the object to be blasted, then firmly press down the deadman lever (#12). Air and wet blast abrasive will flow into the blast hose and out of the blast nozzle (#11).

**⚠ WARNING**

Do Not aim the blast nozzle towards yourself or any person. A system malfunction or a blocked blast nozzle that clears can trigger accidental start up resulting in injury to personnel.

- 7.6.20. Observe the blast stream and the coating removal rate. Release the deadman lever (#12) to stop blasting.
- 7.6.21. If necessary adjust the abrasive flow with the knob on the Tera Valve™ (#14). Turn clockwise for less abrasive flow, or turn counter-clockwise for more abrasive. Due to the length of the blast hose there will be a slight delay in control of the abrasive flow at the nozzle, therefore allow a few seconds before adjusting further.
- 7.6.22. Note the VPI® decal setting on the side of the Tera Valve cap to view the knob position relative to the abrasive flow. The markings relative to the knob can be used as reference when changing nozzle size or abrasive for different applications.
- 7.6.23. Re-test the blast air, water and abrasive mixture again on a test piece to determine if further adjustment is needed. Release the deadman lever (#12) to stop blasting. Replace screen (#30) and close the lid (#29) to protect against debris from entering blaster vessel.
- 7.6.24. It may be necessary to make further adjustments to the water flow after final abrasive flow adjustments are complete.
- 7.6.25. After blasting is finished for the day it is a good idea to purge the wet abrasive from the blast hose (#10). Turn the abrasive cutoff valve or switch (#62) to the “off” position. Continue to blast until all blast abrasive has been cleared from the blast hose (#10) and you are only getting air and water out of the blast nozzle (#11).

## **7.7 Washdown Operation**

- 7.7.1. Switch the mode selector (#47) to “WASHDOWN MODE”.
- 7.7.2. Turn the water “ON” by pulling out the palm button on the water on/off palm button control valve (#48)
- 7.7.3. Turn the abrasive cutoff valve or switch (#62) to the “OFF” position.
- 7.7.4. With one hand grip the blast hose assembly (#10) and with the other hand press in the deadman (#12) safety button. To begin wash down, aim the blast nozzle (#11) at the object to be cleaned, then firmly press down the deadman lever (#12). Air and water will flow into the blast hose and out of the blast nozzle (#11).
- 7.7.5. Turn the wash down pressure regulator knob (#46) to set the blast/wash down air pressure gauge (#49) to the desired wash down pressure. See Section 5.18 for procedure (recommended starting point is 50 psi, then adjust for the desired results).
- 7.7.6. Leave the water differential pressure setting as it was during wet blasting, but it can be adjusted if necessary. Turn the water differential pressure regulator (#50) knob counter clockwise for less water and clockwise for more water. Release the deadman lever (#12) to stop wash down.

## 7.8 Blow Off Operation

- 7.8.1. Switch the mode selector (#47) to “BLAST MODE”.
- 7.8.2. Turn the water “Off” by pushing in the palm button on the water on/off palm button control valve (#48)
- 7.8.3. Turn the abrasive cutoff valve or switch (#62) to the “OFF” position.
- 7.8.4. With one hand grip the blast hose assembly (#10) and with the other hand press in the deadman (#12) safety button. To begin blow off, aim the blast nozzle (#11) at the object to be dried or cleaned, then firmly press down the deadman lever (#12). Air only will flow into the blast hose and out of the blast nozzle (#11).
- 7.8.5. Turn the blast air pressure regulator knob (#44) to set the blast/wash down air pressure gauge (#49) to the desired blow off pressure. See Section 5.17 for procedure. Release the deadman lever (#12) to stop blow off.

## 7.9 Ending the Blast Operation

- 7.9.1. Close the air inlet ball valve (#3). The ball valve is closed when the handle is fully turned to the position shown in Figure 7.1 (handle perpendicular to body). The handle tab will bottom against the ball valve body in the closed position.

### CAUTION

Do not turn off the air compressor and allow the abrasive blaster air pressure to back flow through the air supply system. Back flow will carry abrasive into the moisture trap (#7) and contaminate the controls.

- 7.9.2. Completely open the drain ball valve (#8) at the bottom of the moisture trap (#7) to allow all the accumulated moisture to be drained out. Close the ball valve after draining.
- 7.9.3. Completely depressurize the abrasive blast vessel (#1) by slowly opening the blowdown ball valve (#4). See Section 6.2 for blowdown procedure.

### WARNING

Airborne particles and loud noise hazard from the blowdown exhaust air can cause serious injury and loss of hearing. Wear approved eye and ear protection. Stay clear of blowdown air path. DO NOT place hands or other body parts in the blowdown air path. Make sure no personnel are in the blowdown air path.

### CAUTION

Do Not leave the abrasive blaster pressurized during long periods of no usage. An undetected air leak can cause costly damage to the pressure vessel at the handway or abrasive inlet.

- 7.9.4. For long periods of non-usage remove remaining blast abrasive from blast vessel to minimize moisture contamination. Close lid (#29) to protect against debris from entering blast vessel. Confirm that the retractable spring loaded plunger (#42) is in the locked closed position on the lid (#29).

### CAUTION

Steel abrasive left inside the blast vessel can be contaminated by moisture and solidify inside causing costly damage.

- 7.9.5. In cold weather water must be drained from the water pump to avoid freezing which can cause costly damage. Turn off the water supply and open the water pump priming ball valve (#56) to drain the water.

### CAUTION

In cold weather water must be drained from the water pump to avoid freezing which can cause costly damage.

## 8.0 Maintenance and Inspection Instructions

### DANGER

The abrasive blaster is a Pressurized Vessel. Propelled objects will cause serious injury or death. Depressurize vessel before performing any maintenance. See Section 6.2.

### WARNING

For proper operation, maintenance should be performed with the assistance of a qualified serviceman.

- 8.1. **Blaster Pressure Vessel:** The ASME Code is a standard covering materials, design, fabrication, and installation. Vessel integrity subsequent to purchase is the responsibility of the owner and/or user. At intervals required by state law and/or local authorities, the vessel should be subjected to a hydrostatic test as described in the ASME Code, Section VIII, Division 1. Do Not subject the abrasive blaster pressure vessel to a pneumatic proof test exceeding the maximum allowable working pressure. In no case should the hydrostatic test pressure exceed 1.3 times the maximum allowable working pressure (MAWP) shown on the pressure vessel nameplate (#24). Thoroughly clean and dry the vessel before re-assembly. Moisture or debris left in vessel can cause equipment malfunction.
- 8.2. **Blaster Pressure Vessel:** Any damage to an abrasive blaster can make it unsafe. Inspect the exterior of the abrasive blast vessel weekly for corrosion, pitting, or other damage (i.e. dents, gouges or bulges). If damaged, take out of service immediately and have it inspected and/or repaired by a qualified facility. Contact Axxiom Manufacturing, Inc. for technical support.
- 8.3. **Blaster Pressure Vessel:** The interior condition of the abrasive blast vessel (#1) should be inspected quarterly. Pitting caused by corrosion will reduce the wall thickness of the vessel. If excessive corrosion is found, have the abrasive blast vessel inspected by a qualified facility. Contact Axxiom Manufacturing, Inc. for technical support. Refer to the ASME Data Report for the vessel minimum thickness.  
Check the pressure vessel internal piping for corrosion, cracks, wear, holes, or any other damage. Repair or replace damaged components. See Figure 8.1 and Section 9.11.
- 8.4. **Popup Assembly:** The popup alignment and operation is tested by the manufacturer, however vibration and creeping during shipment may cause the internal popup support piping to shift resulting in misalignment. Check the popup gap and alignment prior to initial usage and weekly thereafter. Inspect the popup as follows:
  - a) Depressurize the abrasive blaster per Section 6.2.
  - b) Disconnect air supply hose from the crowfoot (#2).
  - c) Inspect the popup gasket (#6) and popup head (#5) sealing surfaces for wear or deformations. Replace either if necessary.
  - d) Check that the popup is centered within the gasket opening. If necessary, use a pry bar as a lever between the popup and gasket to deflect the internal support piping and shift the popup to the center of the gasket opening.
  - e) Check the popup gap (distance between the popup surface and the gasket). It should be between 5/8" and 7/8". See Figure 8.1. An excessive gap is created by a vertical nipple that is too short. An excessive gap will expose the top of the vertical nipple to abrasive when the popup closes which could result in premature wear to the popup.
  - f) After checking the alignment and gap, the blast vessel can be re-pressurized and the popup is then checked for leaks. If a leak is present, repeat the above steps to isolate the problem.

### WARNING

Pinch point hazard. Vessel pressurization will close the popup. Keep hands and fingers away from popup. Disconnect air supply prior to performing popup maintenance.

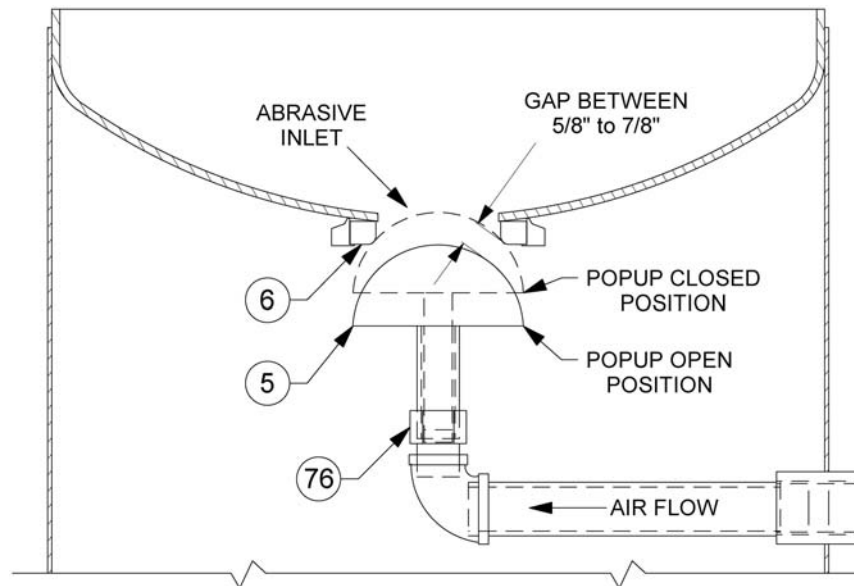

**Figure 8.1 – Standard Popup Assembly and Internal Piping**

- 8.6. ***Blast and Air Hoses, Piping, Pipe Fittings, and Wires:*** All air hoses, blast hoses, control hoses, pipe, pipe fittings, and wires are wear items on any abrasive blaster. These components should be inspected daily for air leaks, cracks, holes, dry rotting, cuts, or any other damage. Repair or replace any components that show any signs of wear or damage.

**⚠ DANGER**

Damaged hoses, piping, pipe fittings or wires can cause system malfunctions and can result in serious injury or death to operating personnel.

Blast hoses are a high wear component of the abrasive blast system. Sharp bends in the blast hose create high wear points resulting in soft spots where the blast hose wall has thinned. These areas can rupture while blasting. Check the full length of the blast hose assembly for soft spots caused by wear. To protect against serious injury to personnel replace blast hoses with soft spots. **Note:** Static electricity is generated by the abrasive flow through the blast hose. To minimize chance of static electrical shock to operating personnel only use anti-static blast hose, properly electrically bond the blast nozzle, blast hose couplings, and the equipment, and properly install a earth ground to the abrasive blaster. See Section 5.12.

**⚠ WARNING**

Worn blast hose assemblies can rupture while blasting and the resulting abrasive blast stream can cause serious personal injury.

**⚠ WARNING**

Longer blast hoses require longer time to dissipate the blast stream when the deadman is released to end the blast operation. This extended dissipation time increases the risk of injury if there is an accidental loss of control of the blast hose.

**⚠ CAUTION**

Static electric shock hazard. To minimize chance of static electrical shock to operating personnel only use anti-static blast hose, properly electrically bond the blast nozzle, blast hose couplings, and the equipment, and properly install a earth ground to the abrasive blaster. See Section 5.12.

- 8.7. **Blast and Air Hose Couplings:** All air hose, blast hose, and threaded couplings have two pin holes that align when connected. To protect against accidental hose disconnections, safety pins must be installed through these holes. Each hose connection must also include a hose whip check that will hold the hose if there is an accidental disconnection. Connect one loop to each side of the connection and stretch out as shown in Figure 8.2 below. Check hose connections daily and replace missing or damaged pins and whip checks.

**⚠ WARNING**

Failure to install safety pins on all air and blast hose couplings can result in hose disconnects and could result in serious injury or death.

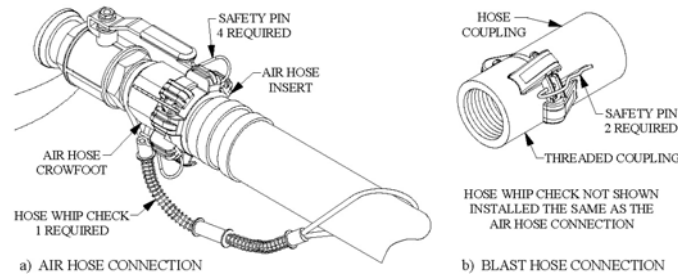

**Figure 8.2 – Hose Connection Disconnect Protection**

- 8.8. **Blast and Air Hose Gaskets:** All air hose, blast hose, and threaded couplings have gaskets that seal the connection. To reduce loss of air pressure and/or premature abrasive wear replace these gaskets when leaks are found. Inspect the couplings daily for leaks and wear. Replace gaskets when visible wear or leaks are found. When installing or replacing hose couplings cut the hose end square for secure fit (see Figure 8.3). To insure proper coupling connection always use fittings that are the same brand. See the drawings and part lists in Section 9.0.

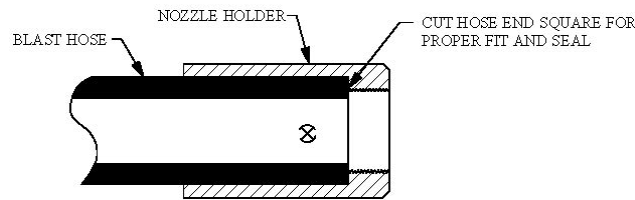

**Figure 8.3 – Hose End Fit up**

- 8.9. **Blast Nozzle(s):** Remove the blast nozzle daily and check the jacket and thread condition. Check nozzle throat diameter. An over-sized throat diameter reduces blast efficiency. Replace the blast nozzle if worn or damaged.
- 8.10. **Valves:** Thompson® Valves, Tera Valves™, Automatic air valves, MV3® Valves, Combo Valve®, control valves, and deadman valves should be disassembled and inspected quarterly, or more frequently if heavily used. Ball valves should open and close without difficulty and should not leak air. Repair or replace any component that shows signs of damage. The Thompson® Valve cylinder should be cleaned and lubricated with an anti-seize compound. Replace parts as needed with Schmidt® original factory replacement parts furnished by an authorized Schmidt distributor. Once a day check if air is leaking from end of blast nozzle when the blast operation is off. A worn valve seat or trash in the valve usually causes this (See Section 11.3.5). Clean or replace by removing the four bolts in the base of the valve to allow disassembly. Refer to valve drawings in Section 9.0 and specific valve maintenance manual.

**⚠ DANGER**

Depressurize vessel before performing any maintenance. See Section 6.2. Removing the Tera valve bolts with the bulk blaster pressurized will result in serious injury or death.

**⚠ WARNING**

Use of replacement components that are not Schmidt original factory replacement parts may result in equipment failure which can result in serious personal injury.

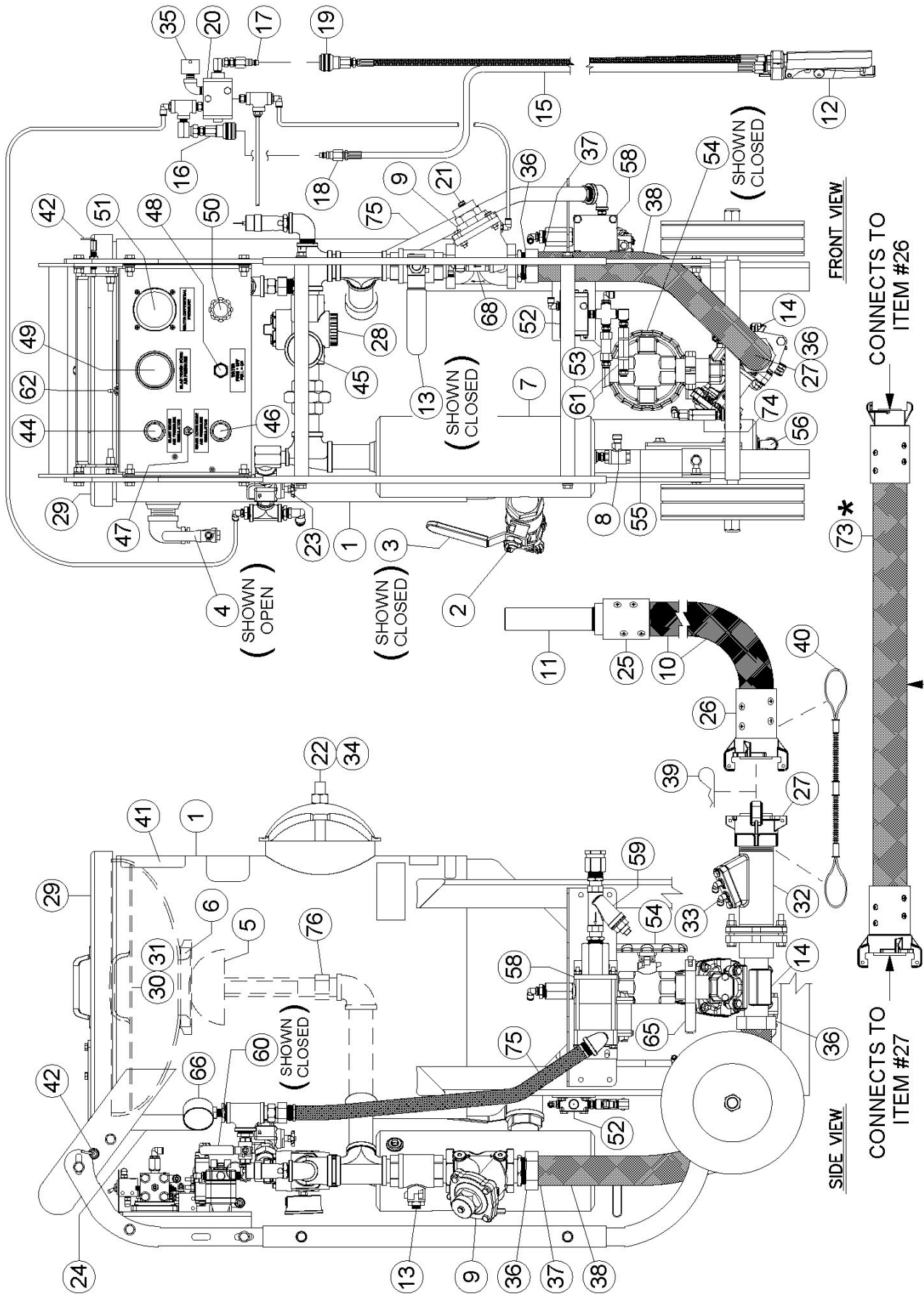

Figure 8.4 – AmphiBlast™ With Pneumatic Blast Controls



- 8.11. **Blowdown Ball Valve:** The blowdown ball valve (#4) is used to depressurize the abrasive blaster pressure vessel (#1). See Figure 8.4. The blowdown air flow can carry abrasive from inside the pressure vessel which can wear the blowdown ball valve (#4) and piping. This wear will cause the blowdown ball valve (#4) to be difficult to open and/or close, and/or result in the inability to close properly (air leaks), and/or wear of the attaching pipe fittings. If and when any of these conditions develop they will be noticeable during daily blowdown operation. When any malfunction is detected the blowdown ball valve (#4) and attaching fittings should be replaced.

**⚠ WARNING**

Worn blowdown valve, piping, and pipe fittings can rupture during operation which can cause serious injury or death to operating personnel. Always repair or replace worn or damaged components.

The blowdown ball valve (#4) should be inspected for proper operation before each use of the abrasive blaster. Depressurize the abrasive blaster per Section 6.2 then confirm that the blowdown ball valve handle turns open and closed without difficulty. Difficulty in turning the blowdown ball valve handle indicates grit contamination within the moving parts of the valve. **Note:** Once maintenance is completed as detailed below and the abrasive blaster is re-pressurized confirm there is no air leakage when the blowdown ball valve (#4) is closed. The ball valve is closed when the handle is fully turned to the position shown in Figure 8.4 (handle perpendicular to body). When any malfunction is detected the blowdown ball valve (#4) and attaching fittings should be replaced.

- 8.13. **PPE:** Check daily to verify that all personal protective equipment is available for each blast operator. Check daily to verify that all personal protective equipment is in good operating condition. Consult the operating and maintenance instructions provided by the manufacturer of each PPE item. See Section 3.10 and reference OSHA 29 CFR 1910 Subpart I.

**⚠ WARNING**

Failure to use personal protective equipment could result in serious injury or death.

- 8.14. **Warning Decals:** Check monthly to verify that all the warning decals are in position and legible. See Section 0.0 for full descriptions and locations.

**⚠ DANGER**

Failure to maintain warning decals risks the possibility of not alerting the abrasive blaster operator to potential dangers which can result in serious injury or death. See Section 0.0.

- 8.15. **Handway Assembly:** Refer to Section 6.4 for the handway (#22) installation and inspection procedures.
- 8.16. **Moisture Separator and Strainer:** With the air supply on, once a day completely open the moisture separator drain ball valve (#8) and the control air strainer petcock (#23) to purge all moisture and debris. Purge for about one minute then close the ball valve and petcock.
- 8.17. **Blast Air Signal Micron Filter:** Once a quarter remove and clean the blast air signal micron filter element (#68).
- 8.18. **Water Supply Strainer:** Once a week remove and clean the water strainer element (#59).
- 8.19. **Water Pump:** Once a quarter disassemble, clean, and re-lubricate air drive section of the water pump (#58). Refer to manufacturer manual Section 14.0 for maintenance requirements.
- 8.20. **Washdown Water Micron Filter:** Once a month remove and clean the washdown water micron filter element (#74).

### 8.21. *Maintenance Schedules Quick Reference Charts*

**Note:** The below schedule is the minimum requirements for inspection and maintenance; however, the equipment should be inspected and serviced immediately if abnormal operation is detected.

AMPHIBLAST SYSTEM MAINTENANCE SCHEDULE					
Item	Maintenance required	Daily	Weekly	Monthly	Quarterly
Blaster Vessel	Hydrostatic Test See Section 8.1.	As required by state law and/or local authorities			
Blaster Vessel	Check for exterior damage (corrosion, dents, bulges). See Section 8.2.		X		
Blaster Vessel	Check for interior wear, corrosion, & pitting. Check internal piping for wear or damage. See Section 8.3.				X
Popup	Check sealing surfaces, alignment and gasket to popup gap. See Section 8.4.		X		
Blast & Air Hoses	Check air & blast hoses for soft spots, wear, cracks, or air leaks See Section 8.6.	X			
Remote Control Hoses	Check control air hoses for soft spots, wear, cracks, or air leaks See Section 8.6.	X			
Blaster Piping & Pipe Fittings	Check pipe & pipe fittings for wear, cracks, or air leaks See Section 8.6.	X			
Remote Control Wires	Check wiring for bare spots, fraying, cuts, or cracks See Section 8.6.	X			
Blast & Air Hose Couplings	Check for safety pins and whip checks See Section 8.7.	X			
Hose Coupling Gaskets	Check for leaks at the air, blast, & and threaded hose coupling gaskets See Section 8.8.	X			
Blast Nozzle	Check blast nozzle threads and jacket for wear, damage, or air leaks. See Section 8.9.	X			
Valves	With valves off and blast vessel pressurized check for air leakage at blast nozzle. See Section 8.10	X			
Valves	Disassemble, inspect, and lubricate. Check for proper operation. See Section 8.10.				X
Blowdown Ball Valve	Check for proper opening and closing. Check for wear, damage, or air leaks. See Section 8.11.	Before every use			
Personal Protective Equipment	Check for presence and condition of all personal protective equipment. See Sections 3.10 and 8.13.	X			
Warning Decals	Check for presence and condition of all warning decals. See Sections 0.0 and 8.14.			X	
Handway Assembly	Check gasket for wear, cracking, or dry rotting. Check sealing surfaces for damage. See Sections 6.4 and 8.15.			X	
Moisture Separator & Strainer	Fully open separator drain ball valve and strainer petcock to purge moisture and debris. See Section 8.16.	X			
Blast Air Signal Micron Filter	Disassemble to remove and clean strainer element. See Section 8.17.				X
Water Supply Strainer	Disassemble to remove and clean strainer element. See Section 8.18.		X		
Water Pump	Disassemble clean and lubricate air drive system per manufacturer's recommendation. See Section 8.19.				X
Washdown Water Micron Filter	Disassemble to remove and clean strainer element. See Section 8.20.			X	

## **9.0 Drawings and Parts Lists**

**The following pages contain drawings representing typical blast control systems and components. Determine the type of control system the abrasive blast system is equipped with (pneumatic or electric controls) then reference the appropriate drawing and parts list to determine the required parts. To insure the proper operation of the blast system only use Schmidt® original factory replacement parts furnished by an authorized Schmidt distributor. See Section 1.39 and Section 12.2.12.**

## 9.1(a) Amphiblast™ Pneumatic Control System Parts List

ITEM	PART NUMBER	DESCRIPTION
38	4102-00X	Air hose (specify size)
39	7119-002	Safety pin, airblast hose coupling
40	8710-98778	Hose whip check (safety cable)
41	7031-999-02	Warning decal kit
42	5010-000-03	Retractable spring plunger
43	-----	-----
44	2001-011	Blast pressure regulator
45	2010-009-01	Inlet pressure gauge 0-160 psi
46	8200-000-26	Wash down pressure regulator 0-100 psi
47	8200-000-17	Mode selector switch
48	2229-301	Water on/off palm button control valve (C3) (See Section 9.12)
49	8710-40007A	Blast/wash down air pressure gauge 0-160 psi
50	2006-002	Water differential pressure regulator
51	8200-000-12	Water differential pressure gauge 0-30 psi
52	8200-000-09	Water control valve (C5) (See Section 9.7)
53	8200-000-29	Check valve, 1/4" (blast spray)
54	2401-907	Abrasive shut-off valve
55	8221-030-00CP	Snubber tank
56	2401-502	Water pump priming ball valve 1/4"
57	4227-305-05	Garden hose coupling, 3/4" x 3/4"
	4227-305-99	Garden hose coupling gasket, 3/4"
58	2210-002	Water pump
59	2300-904-00	Strainer, 1/2" (200 mesh)
60	2401-502	Water pump air supply ball valve, 1/4"
61	8200-000-77	Check valve, 1/4" (wash down spray)
62	8200-000-17	Abrasive cutoff Switch
63	-----	-----
64	-----	-----
65	8710-98502	Clamp fitting, 1-1/4"
	8710-92301S	Tri-clamp (spring loaded)
	8710-98503	Tri-clamp o-ring
66	8200-000-37	Water pump air supply pressure gauge 0-60 psi
67	2229-000	Pneumatic control valve (C4) (See Section 9.6)
68	8710-98578	Filter 1/4" (2 micron)
69	-----	-----
70	-----	-----
71	-----	-----
72	-----	-----
73	8200-000-51	Blast hose adapter, 1 1/2" x 3 ft (See section 5.12)
74	2301-402-40	Filter 1/4" mnpt comp 40 micron
	2301-402-99	Filter element & seal kit
75	4101-005	Push-on hose, 3/4"
76	2497-706	Grit Suppression Valve, 1"

ITEM	PART NUMBER	DESCRIPTION
1	8221-030-00AP	Amphiblast Vessel (Painted)
2	4211-10X	Crowfoot, 4-lug (specify size)
	4211-999	Crowfoot gasket
3	2401-50X	Air inlet ball valve (specify size)
4	2401-502	Blowdown ball valve, 1/4"
5	2100-010-04	Popup Head
6	2100-011	Popup Gasket
7	8221-030-00DP	Moisture Separator (painted)
8	2401-502	Drain ball valve, 1/4"
9	2123-10X	Automatic Air Valve (specify size) (See Section 9.5)
10	4104-XXX-XX	Blast hose assembly (specify size)
11	5000-XXX	Blast nozzle (specify size)
12	2263-002	G2 Deadman valve (See Section 9.8)
13	2401-50X	Choke ball valve (specify size)
14	2130-007D	Tera Valve™, 1-1/4" TC w/diverter plate (See Section 9.4)
	2130-008D	Tera Valve™, 1-1/2" TC w/diverter plate (See Section 9.4)
15	4100-501	Twinline hose assembly, 55 ft
	4100-701	Twinline hose assembly, 110 ft
16	4224-301-02	Female quick connect, 1/4"
17	4224-300-02	Male quick connect, 1/4"
18	4224-300-02	Male quick connect, 1/4"
19	4224-301-02	Female quick connect, 1/4"
20	2229-000	Pneumatic control valve (C2) (See Section 9.6)
21	2014-300	Breather vent, 1/8"
22	7000-001-11	Handway assembly, 6" x 8" with gasket
23	2301-904-90	Strainer, 1/2" (90 micron)
24	-----	Pressure vessel nameplate
25	4215-XXX	Nozzle holder (specify size)
26	4213-XXX	Blast hose coupling (specify size)
27	4214-309-02	Threaded coupling, 2" with gasket
	4214-999-02	Coupling gasket
28	2000-013	Slave regulator, 1-1/4" (non-relieving)
29	5010-030	Lid, 18"
30	5011-036	Drop-in screen, 18" (3/16" mesh)
31	8031-000-91	Rubber trim
32	8200-000-78A	Dual Port Injection Module, 1-1/4" (See Section 9.10)
	8200-000-78	Dual Port Injection Module, 1-1/2" (See Section 9.10)
33	8200-000-82	Spray nozzle
34	7000-001-18	Handway gasket 6" x 8" (SureFit™)
35	2013-402	Dust eliminator, 1/4"
36	4205-10X	Swivel Insert with gasket (specify size)
	4205-10X-99	Insert gasket (specify size)
37	4235-00X	Hose clamp, double bolt (specify size)

# 9.1(b) AmphiBlast™ Pneumatic Control System

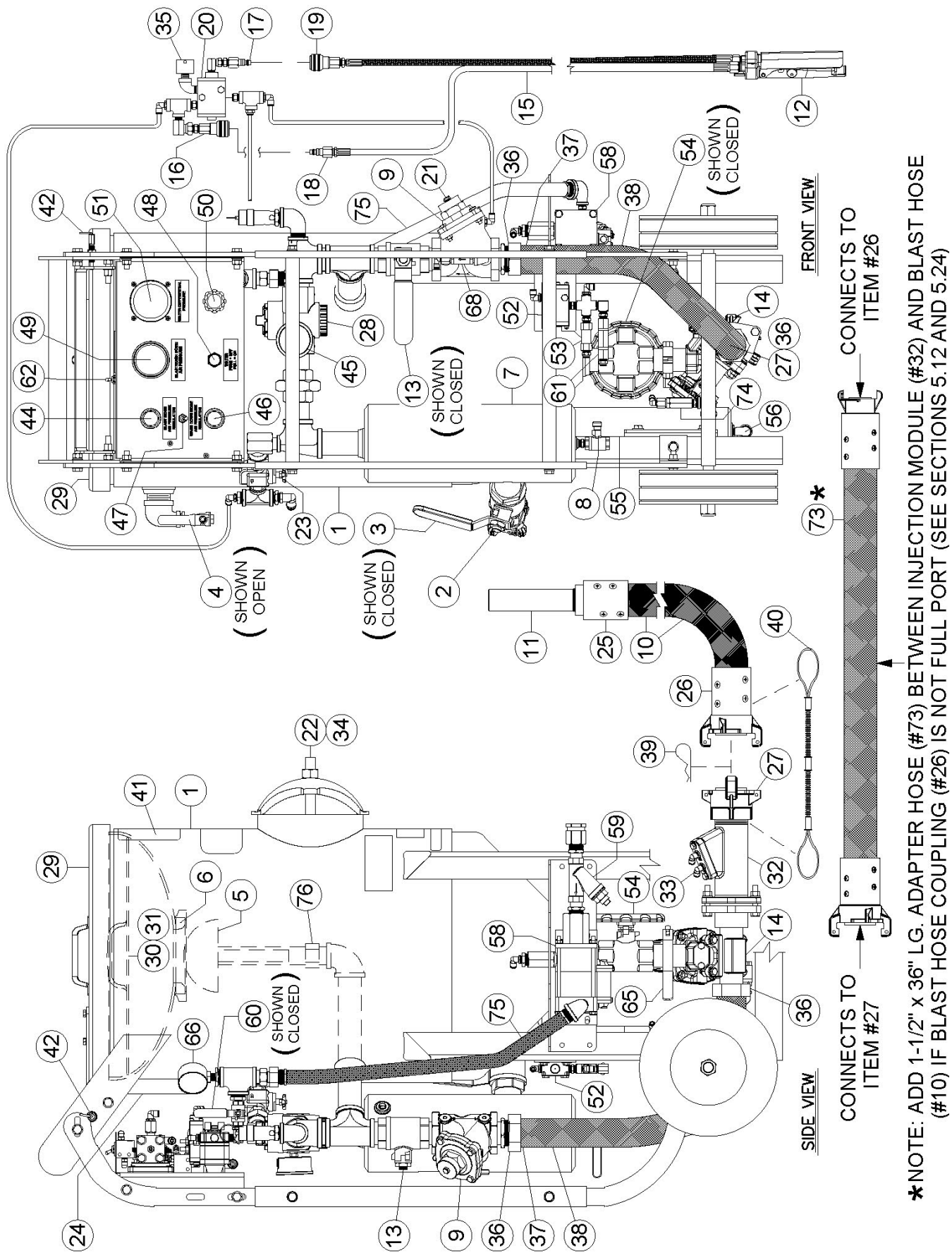

### 9.1(c) AmphiBlast™ Pneumatic Panel Schematic

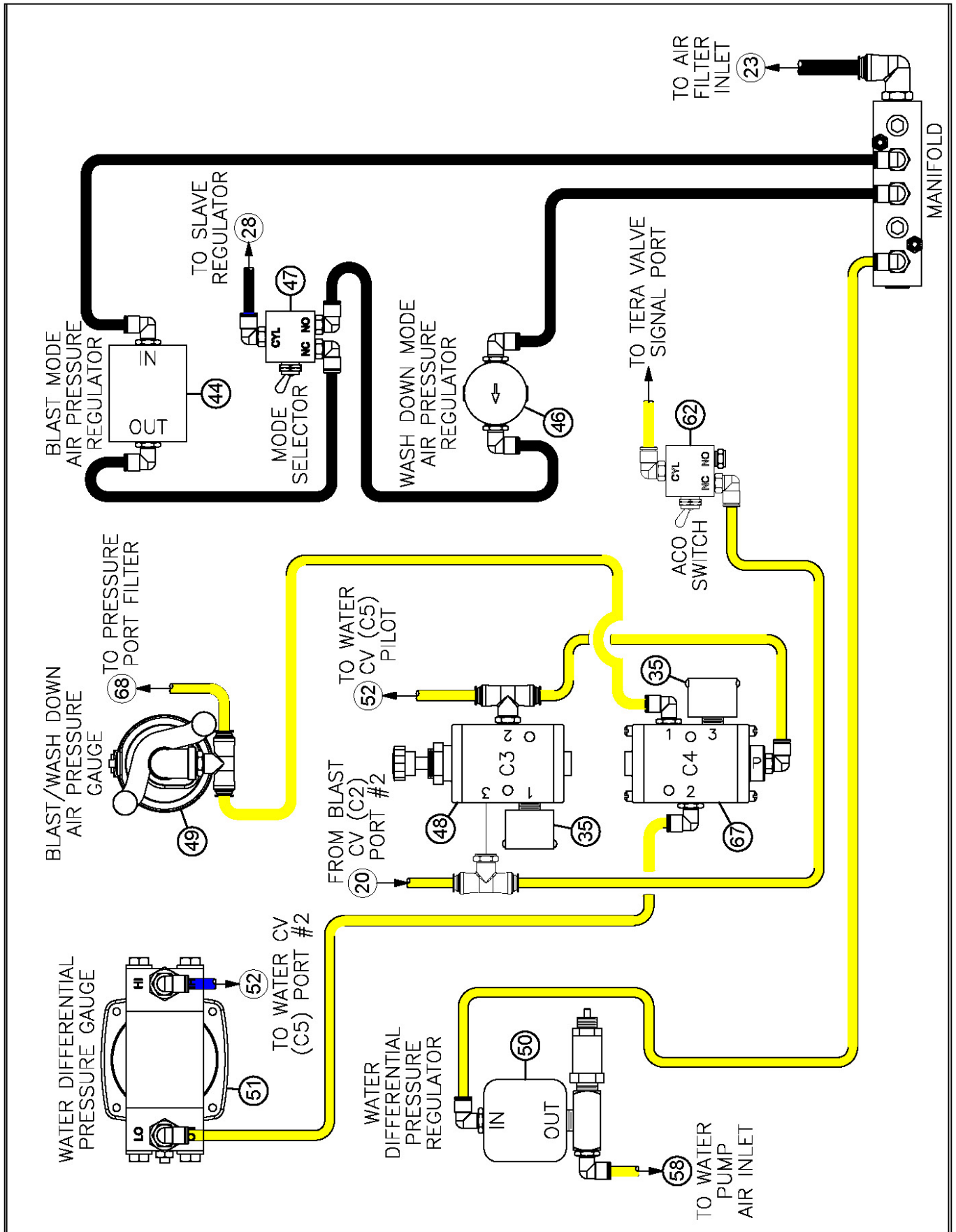

# 9.1(d) AmphiBlast™ Pneumatic Control System Schematic

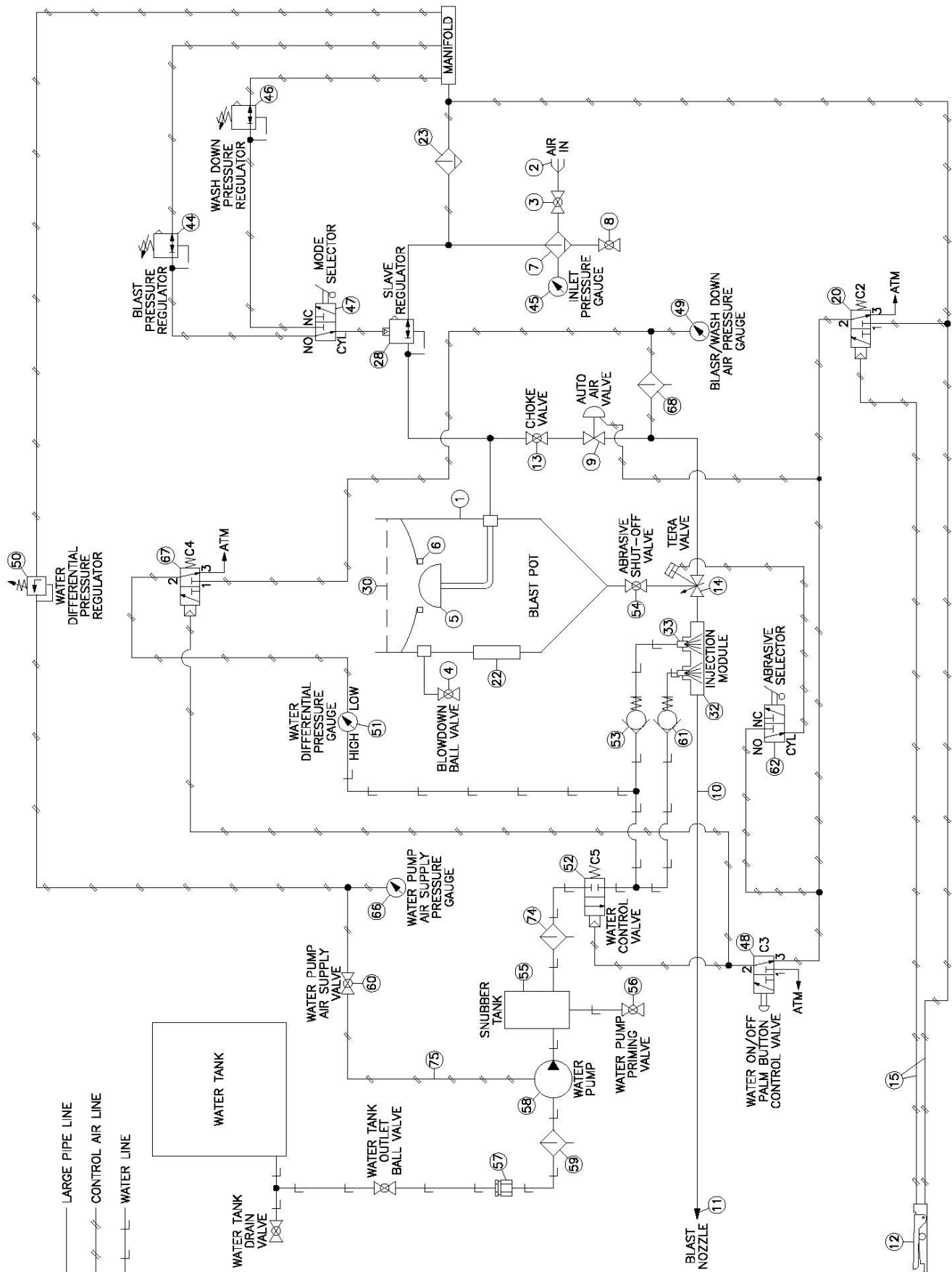

## 9.2(a) AmphiBlast™ Electric Control System Parts List (not ATEX compliant)

ITEM	PART NUMBER	DESCRIPTION
38	4102-00X	Air hose (specify size)
39	7119-002	Safety pin, air/blast hose coupling
40	8710-98778	Hose whip check (safety cable)
41	7031-999-02	Warning decal kit
42	5010-000-03	Retractable spring plunger
43	-----	-----
44	2001-011	Blast pressure regulator
45	2010-009-01	Inlet pressure gauge 0-160 psi
46	8200-000-26	Wash down pressure regulator 0-100 psi
47	8200-000-17	Mode selector switch
48	2229-301	Water on/off palm button control valve (C3) (See Section 9.12)
49	8710-40007A	Blast/wash down air pressure gauge 0-160 psi
50	2006-002	Water differential pressure regulator
51	8200-000-12	Water differential pressure gauge 0-30 psi
52	8200-000-09	Water control valve (C5) (See Section 9.7)
53	8200-000-29	Check valve, 1/4" (blast spray)
54	2401-907	Abrasive shut-off valve
55	8221-030-00C.P	Snubber tank
56	2401-502	Water pump priming ball valve 1/4"
57	4227-305-05	Garden hose coupling, 3/4" x 3/4"
	4227-305-99	Garden hose coupling gasket, 3/4"
58	2210-002	Water pump
59	2300-904-00	Strainer, 1/2" (200 mesh)
60	2401-502	Water pump air supply ball valve, 1/4"
61	8200-000-77	Check valve, 1/4" (wash down spray)
62	8200-000-17	Abrasive cutoff Switch
63	-----	-----
64	-----	-----
65	8710-98502	Clamp fitting, 1-1/4"
	8710-92301S	Tri-clamp (spring loaded)
	8710-98503	Tri-clamp o-ring
66	8200-000-37	Water pump air supply pressure gauge 0-60 psi
67	2229-000	Pneumatic control valve (C4) (See Section 9.6)
68	8710-98578	Filter 1/4" (2 micron)
69	7112-000-16	Junction tee, 12 VDC (sealed connectors)
70	7072-012-03	Power cord, 25 ft. with alligator clips (sealed connectors)
71	-----	-----
72	-----	-----
73	8200-000-51	Blast hose adapter, 1 1/2" x 3 ft. (See section 5.12)
74	2301-402-40	Filter 1/4" mnpt comp 40 micron
	2301-402-99	Filter element & seal kit
75	4101-005	Push-on hose, 3/4"
76	2497-706	Grit Suppression Valve, 1"

ITEM	PART NUMBER	DESCRIPTION
1	8221-030-00AP	Amphiblast Vessel (Painted)
2	4211-10X	Crowfoot, 4-lug (specify size)
	4211-999	Crowfoot gasket
3	2401-50X	Air inlet ball valve (specify size)
4	2401-502	Blowdown ball valve, 1/4"
5	2100-010-04	Popup Head
6	2100-011	Popup Gasket
7	8221-030-00DP	Moisture Separator (painted)
8	2401-502	Drain ball valve, 1/4"
9	2123-10X	Automatic Air Valve (specify size) (See Section 9.5)
10	4104-XXX-XX	Blast hose assembly (specify size)
11	5000-XXX	Blast nozzle (specify size)
12	2263-402-05	G2 Deadman switch (sealed connector) (See Section 9.9)
13	2401-50X	Choke ball valve (specify size)
14	2130-007D	Tera Valve™, 1-1/4" TC w/diverter plate (See Section 9.4)
	2130-008D	Tera Valve™, 1-1/2" TC w/diverter plate (See Section 9.4)
15	7074-055-03	Extension cord, 55 ft (sealed connectors)
	7074-110-03	Extension cord, 110 ft (sealed connectors)
16	7109-300-02	Sealed electric connector, 3-prong female
17	7109-301-02	Sealed electric plug, 3-prong male
18	7109-301-02	Sealed electric plug, 3-prong male
19	7109-300-02	Sealed electric connector, 3-prong female
20	See Section 9.6	Electric control valve (C2)
21	2014-300	Breather vent, 1/8"
22	7000-001-11	Handway assembly, 6" x 8" with gasket
23	2301-904-90	Strainer, 1/2" (90 micron)
24	-----	Pressure vessel nameplate
25	4215-XXX	Nozzle holder (specify size)
26	4213-XXX	Blast hose coupling (specify size)
27	4214-309-02	Threaded coupling, 2" with gasket
	4214-999-02	Coupling gasket
28	2000-013	Slave regulator, 1-1/4" (non-relieving)
29	5010-030	Lid, 18"
30	5011-036	Drop-in screen, 18" (3/16" mesh)
31	8031-000-91	Rubber trim
32	8200-000-78A	Dual Port Injection Module, 1-1/4" (See Section 9.10)
	8200-000-78	Dual Port Injection Module, 1-1/2" (See Section 9.10)
33	8200-000-82	Spray nozzle
34	7000-001-18	Handway gasket 6" x 8" (SureFit™)
35	2013-402	Dust eliminator, 1/4"
36	4205-10X	Swivel Insert with gasket (specify size)
	4205-10X-99	Insert gasket (specify size)
37	4235-00X	Hose clamp, double bolt (specify size)



## 9.2(b) AmphiBlast™ Electric Control System (not ATEX compliant)

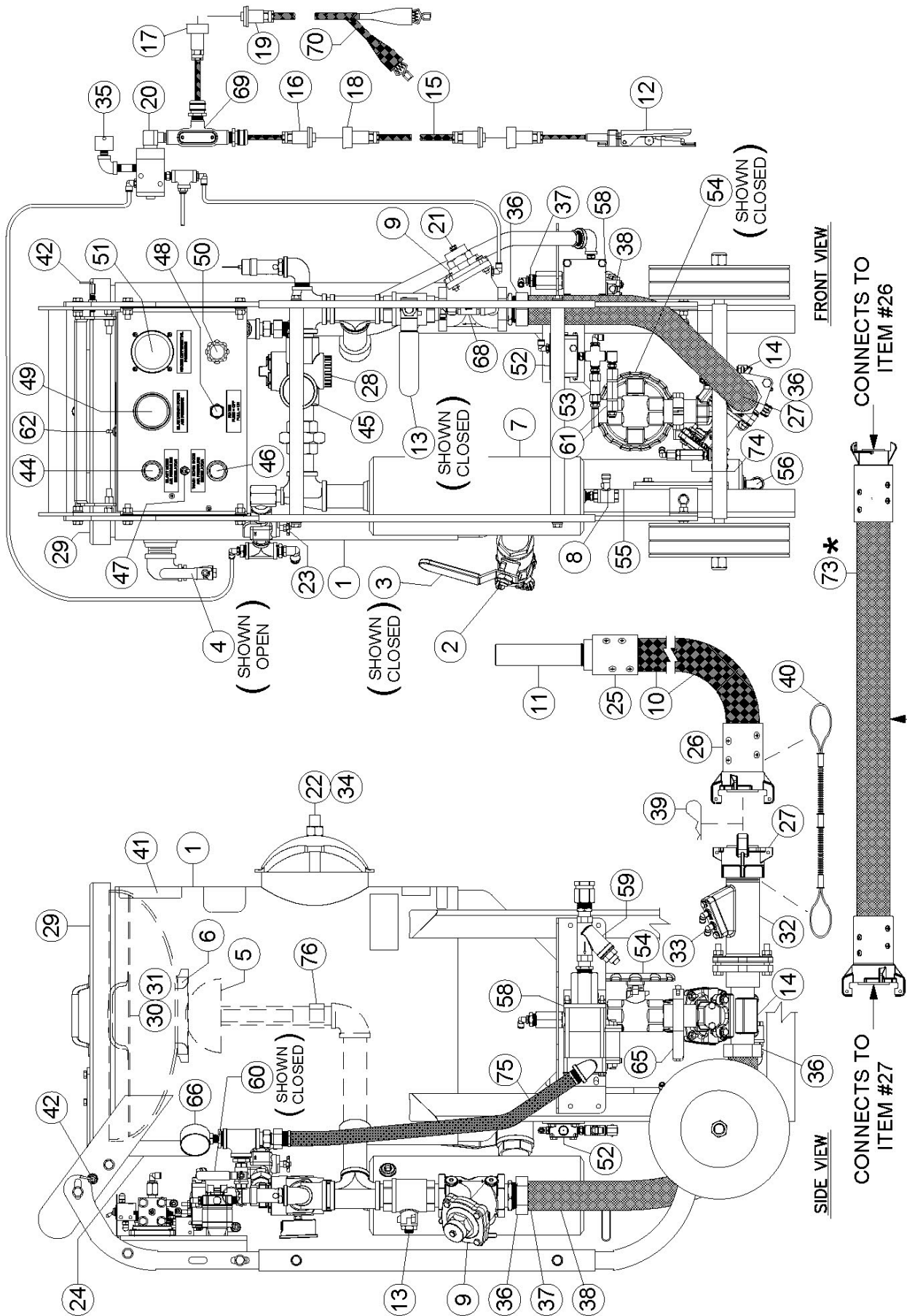

9.2(c) **AmphiBlast™ Electric Panel Schematic (not ATEX compliant)**

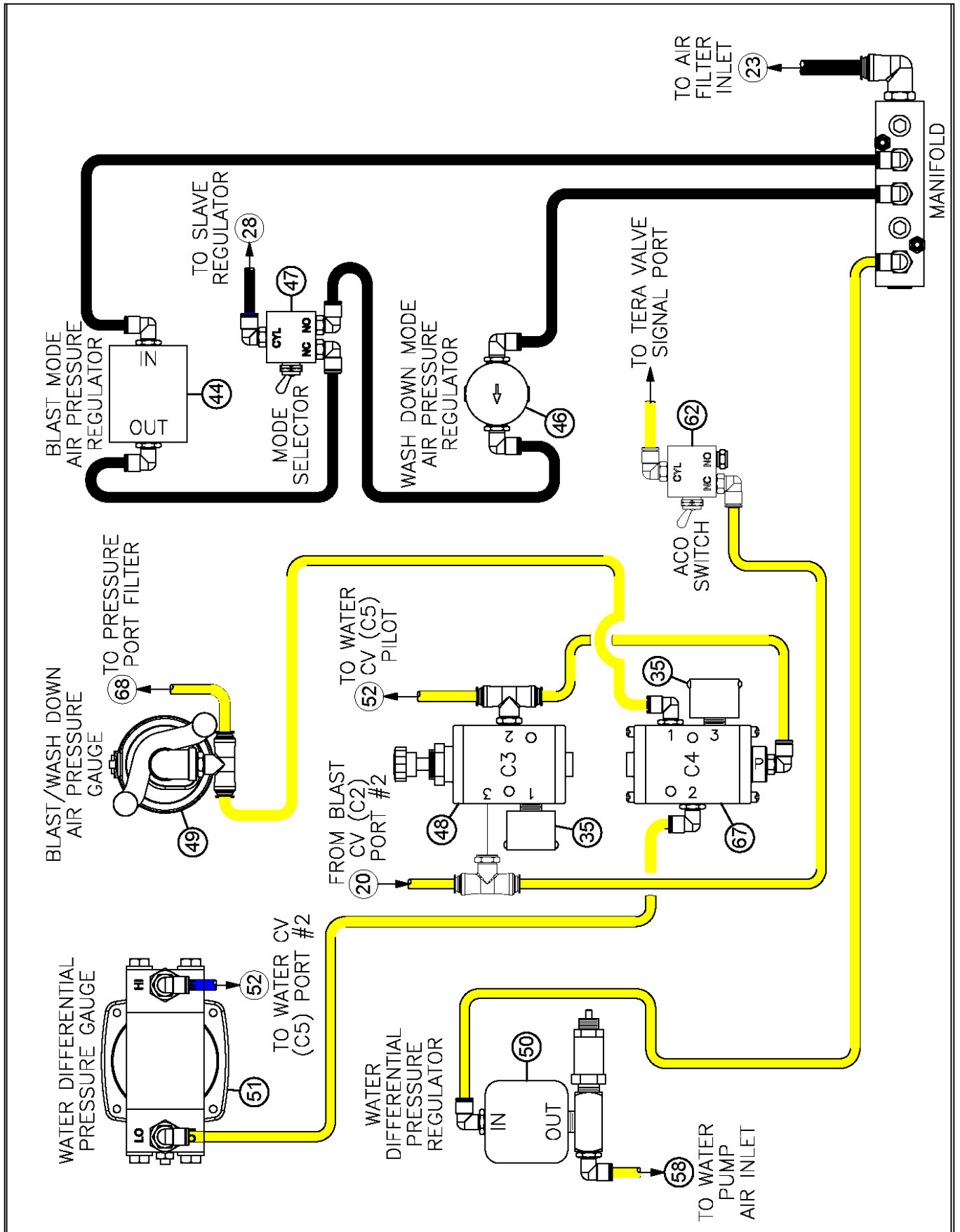

## 9.2(d) AmphiBlast™ Electric Control System Schematic (not ATEX compliant)

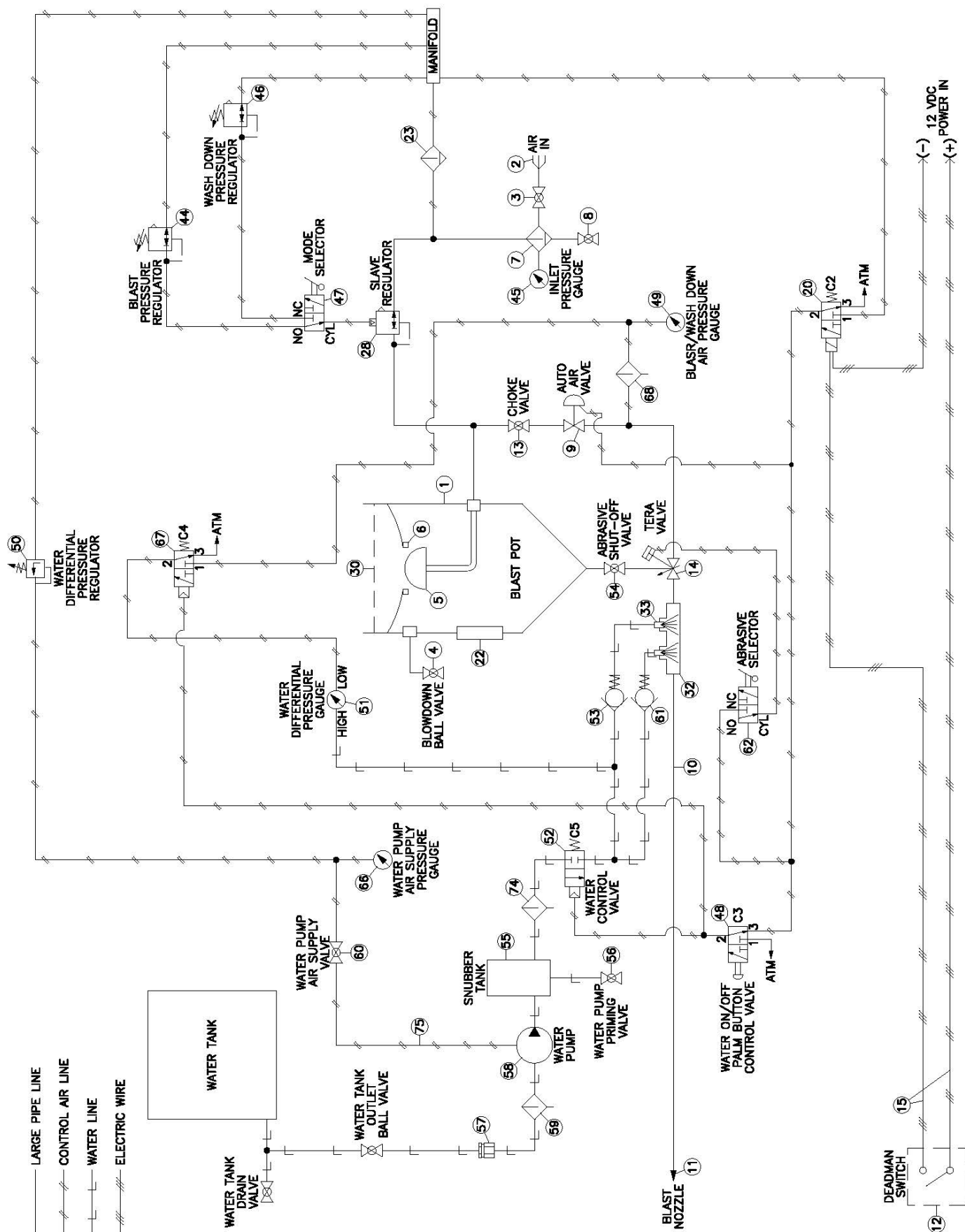

# 9.4 Tera Valve™ With Diverter Plate

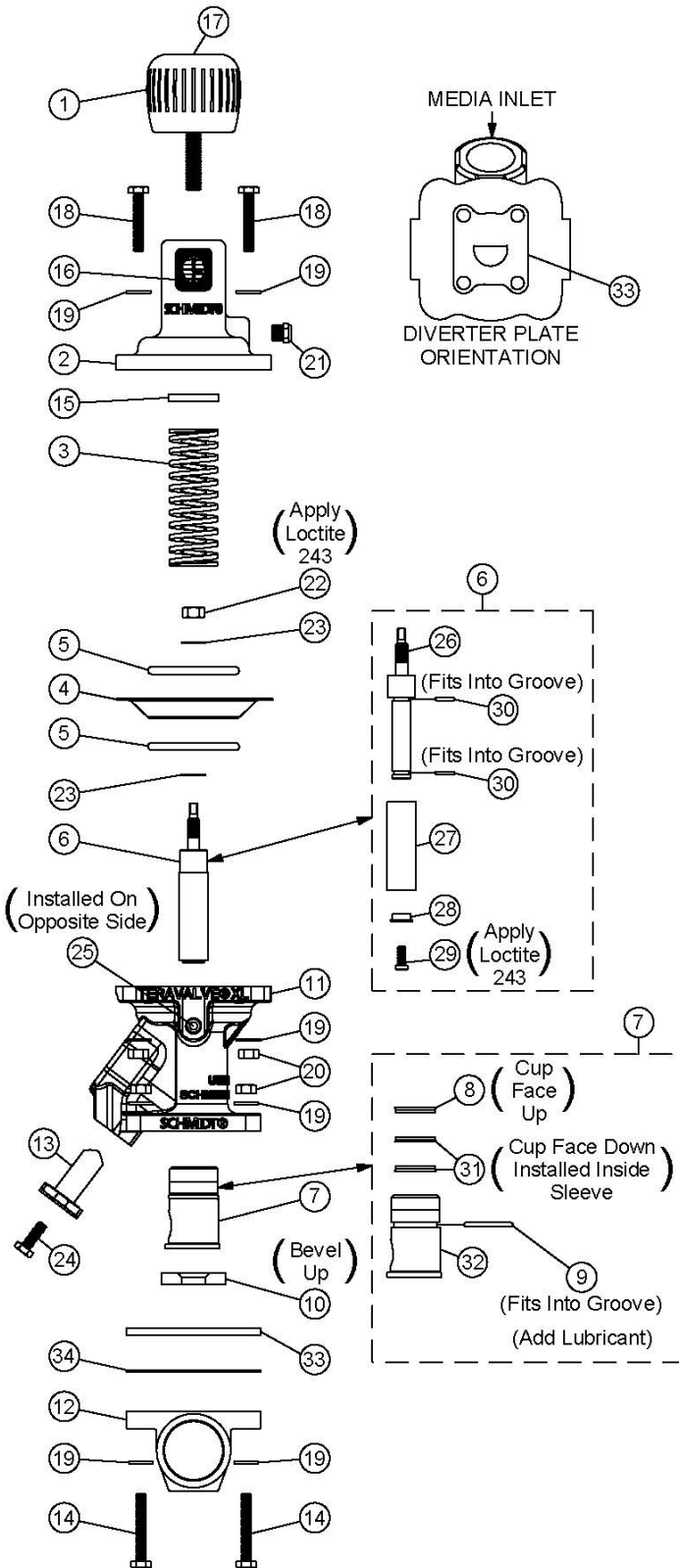

Item	Part No.	Description
	2130-007D	Tera Valve XL, Tungsten Carbide 1 1/4" w/Diverter Plate
	2130-008D	Tera Valve XL, Tungsten Carbide 1 1/2" w/Diverter Plate
1	2130-000-01	Knob
2	2130-000-02	Cap
*3	2130-000-03	Spring
‡4	2130-000-04	Diaphragm
5	2130-000-05	Diaphragm Plate
*6	2130-000-06	Tungsten Carbide Plunger
*7	2130-000-07	Tungsten Carbide Sleeve
‡8	2130-000-08	Plunger Seal
‡9	2130-000-09	Sleeve O-Ring
‡10	2130-000-10	Seat
11	2130-000-11	Body
12	2130-007-12	Base 1 1/4" x 1 1/4"
	2130-008-12	Base 1 1/2" x 1 1/2"
*13	2130-000-13	Cleanout Plug
14	7010-503-53	Hex Bolt, 1/4" UNC x 1 3/4" Lg.
15	2130-000-15	Vibration Disc
16	2130-000-16	Virtual Position Indicator Decal
17	2130-000-17	Knob Decal
18	7010-503-08	Hex Bolt, 1/4" UNC x 1 1/2" Lg.
19	7027-502-02	Flat Washer, 1/4" SAE
20	7017-503	Hex Nut, 1/4" UNC
21	2014-300	Breather Vent, 1/8"
22	7017-505	Hex Nut, 5/16" UNC
‡23	2123-009-01	Gasket
24	7010-503-04	Hex Bolt, 1/4" UNC x 1/2" Lg.
25	3032-100	Plug, 1/8"
*26	2130-000-06A	Modular Plunger Stainless Steel Core
*27	2130-000-06B	Modular Plunger Tungsten Carbide Sleeve
*28	2130-000-06C	Modular Plunger End Cap
*29	2130-000-06D	Modular Plunger End Cap Screw, 10-32 UNF x 1/2" Lg.
*30	2130-000-06E	Modular Plunger O-Ring
*31	2130-000-08	Plunger Seal (Remove O-Rings)
*32	2130-000-07P	Tungsten Carbide Sleeve
*33	8200-000-67	Amphiblast Diverter Plate
‡34	8200-000-68	Amphiblast Diverter Plate Gasket
* Included In Replacement Parts Kit (2130-000-99D)		
+ Included In Replacement Parts Kit, Seals Only (2130-000-98D)		

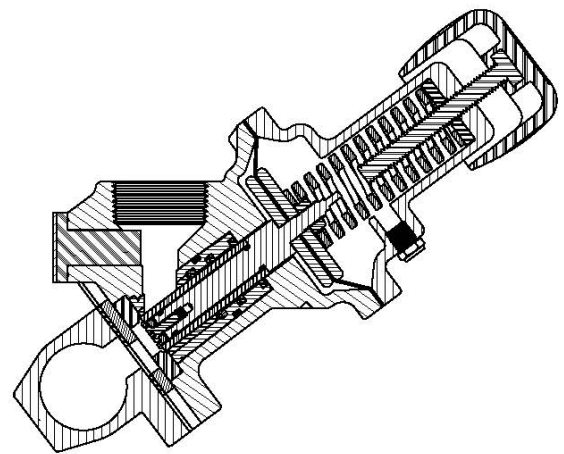

## 9.5 Automatic Air Valve

2123-106 1" Valve		
No.	Part No.	Description
	2123-006-99	Replacement Parts Kit
	2123-006-97	Hard Parts Kit
1.*	2123-007-20	Gasket
2.*	2123-006-02	Diaphragm
3.*	2123-006-03	O-ring
4.	2123-006-04	Retainer Bushing
5.*	2123-007-05	O-ring
6.+	2123-006-06	Disk Retainer
7.*	2123-006-07	O-ring
8.	2123-006-08	Seat
9.+	2123-006-09	Disc Plate
10.	"Deleted"	Lock Washer, Internal
11.*	7082-504	Lock Nut
12.	2123-106-12	Cap
13.*	2123-006-13	Lock Nut
14.	7010-503-06	Cap Screw
15.+	2123-006-15	Diaphragm Plate
17.	7082-503	Lock Nut
18.	2123-006-18	Body, 1"
19.**	2123-006-19	Shaft
20.*	2123-007-20	Gasket
21.*	2123-006-21	Disc
22.**	2123-106-22	O-ring
23.+	2123-106-23	Spring Retainer
24.	2123-106-24	Spring
25.*	2014-300	Vent, 1/8"
26.*	2123-007-20	Gasket

\* Included In Replacement Parts Kit

+ Included In Hard Parts Replacement Kit

2123-107 1 1/4" Valve		
No.	Part No.	Description
	2123-108	1 1/2" Valve
	2123-007-99	Replacement Parts Kit
	2123-007-97	Hard Parts Kit
1.*	2123-009-01	Gasket
2.*	2123-007-02	Diaphragm
3.*	2123-007-03	O-ring
4.	2123-007-04	Retainer Bushing
5.*	2123-007-05	O-ring
6.+	2123-007-06	Disk Retainer
7.*	2123-007-07	O-ring
8.	2123-007-08	Seat
9.+	2123-007-09	Disc Plate
10.	"Deleted"	Lock Washer, Internal
11.*	7082-504	Lock Nut
12.	2123-107-12	Cap
13.*	7082-506	Lock Nut
14.	7010-503-07	Cap Screw
15.+	2123-007-15	Diaphragm Plate
17.	7082-503	Lock Nut
18.	2123-007-18	Body, 1 1/4"
	2123-008-18	Body, 1 1/2"
19.**	2123-007-19	Shaft
20.*	2123-007-20	Gasket
21.*	2123-007-21	Disc
22.**	2123-107-22	O-ring
23.+	2123-107-23	Spring Retainer
24.	2123-107-24	Spring
25.*	2014-300	Vent, 1/8"
26.*	2123-009-01	Gasket

\* Included In Replacement Parts Kit

+ Included In Hard Parts Replacement Kit

** 2123-108L 1-1/2" High Flow Valve		
No.	Part No.	Description
	2123-109	2" Valve
	2123-009-99	Replacement Parts Kit
	2123-009-97	Hard Parts Kit
1.*	2123-009-01	Gasket
2.*	2123-009-02	Diaphragm
3.*	2123-009-03	O-ring
4.	2123-009-04	Retainer Bushing
5.*	2123-009-05	O-ring
6.+	2123-009-06	Disk Retainer
7.*	2123-009-07	O-ring
8.	2123-009-08	Seat
9.+	2123-007-15	Disc Plate
10.	"Deleted"	Lock Washer, Internal
11.*	7082-506	Lock Nut
12.	2123-109-12	Cap
13.*	7082-506	Lock Nut
14.	7010-505-07	Cap Screw
15.+	2123-009-15	Diaphragm Plate
17.	7082-505	Hex Nut
18.	2123-009-27	Body, 1-1/2" high flow
	2123-009-18	Body, 2"
19.**	2123-009-19	Shaft
20.*	2123-009-01	Gasket
21.*	2123-009-21	Disc
22.**	2123-107-22	O-ring
23.+	2123-109-23	Spring Retainer
24.	2123-109-24	Spring
25.*	2014-300	Vent, 1/8"
26.*	2123-009-28	Washer

\* Included In Replacement Parts Kit

+ Included In Hard Parts Replacement Kit

\*\* 1-1/2" High Flow Valve is Standard On Units Manufactured After July 1, 2008

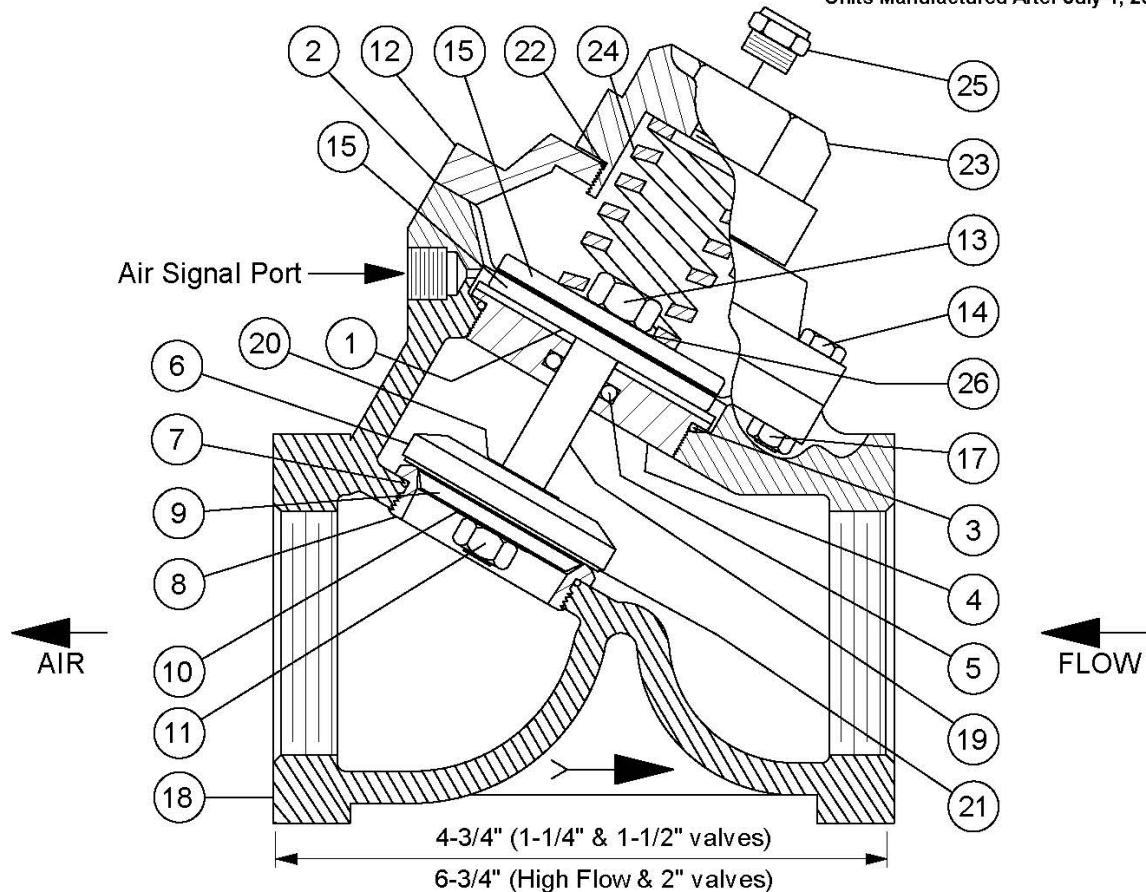

NOTE: With spring closed valve air flow is in opposite direction from arrow on valve body.

## 9.6 Control Valves (Pneumatic and Electric)

Note: Electric control valves are not for use in ATEX applications.

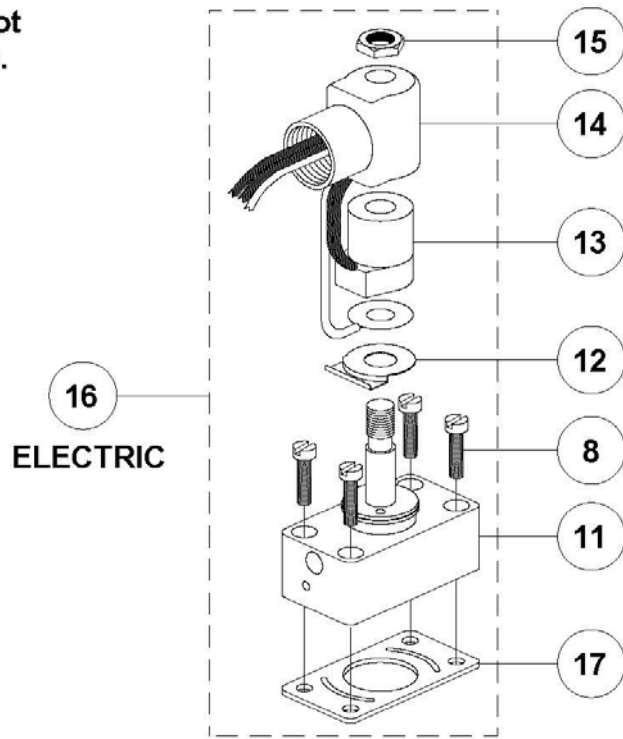
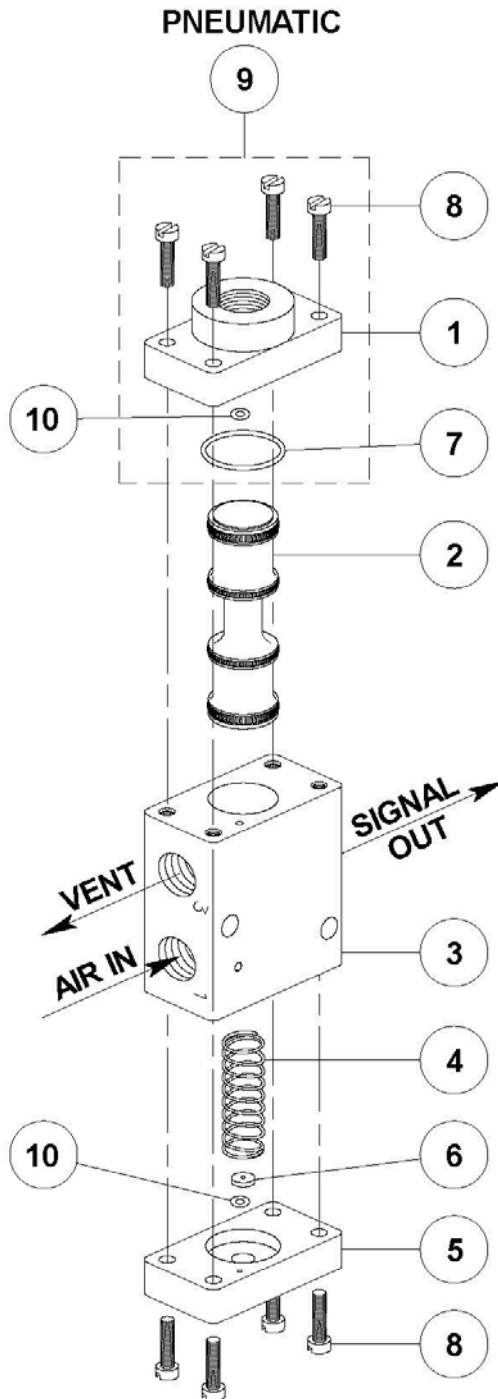

	2229-000	Pneumatic Control Valve
	2229-100	Electric Control Valve, 12 Volt D.C.
	2229-101	Electric Control Valve, 12 Volt A.C.
	2229-102	Electric Control Valve, 24 Volt D.C.
	2229-100	Electric Control Valve, 24 Volt A.C.
	2229-105	Electric Control Valve, 120 Volt A.C.
No.	Part No.	Description
	2229-000-99	Replacement Parts Kit (Pneumatic)
	2229-100-99	Replacement Parts Kit (Electric)
1.	Not Available	Air Operator Cap
2.*+	2229-000-02	Plunger w/O-Rings
3.	Not Available	Valve Body
4.*+	2229-000-04	Spring
5.	Not Available	Spring Retainer
6.*+	2229-000-06	Filter Disk
7.*	2229-000-07	O-Ring (Large)
8.	Not Available	Screw (8)
9.	2229-000-09	Air Operator Assembly
10.*+	2229-000-10	O-Ring (2 ea)
11.	Not Available	Electric Operator Cap
12.	Not Available	Coil Cover Bottom
13.	2229-100-03	Coil 12 Volt D.C.
	2229-101-03	Coil 12 Volt A.C.
	2229-102-03	Coil 24 Volt D.C.
	2229-100-03	Coil 24 Volt A.C.
	2229-105-03	Coil 120 Volt A.C.
14.	Not Available	Coil Cover
15.	Not Available	Nut
16.	2229-100-06	Solenoid Pilot Assembly, 12 Volt D.C.
	2229-101-06	Solenoid Pilot Assembly, 12 Volt A.C.
	2229-102-06	Solenoid Pilot Assembly, 24 Volt D.C.
	2229-100-06	Solenoid Pilot Assembly, 24 Volt A.C.
	2229-105-06	Solenoid Pilot Assembly, 120 Volt A.C.
17. +	2229-100-07	Gasket (Electric Only)
* Included In replacement parts kit-pneumatic		
+ Included In replacement parts kit-electric		

## 9.7 Water Control Valve

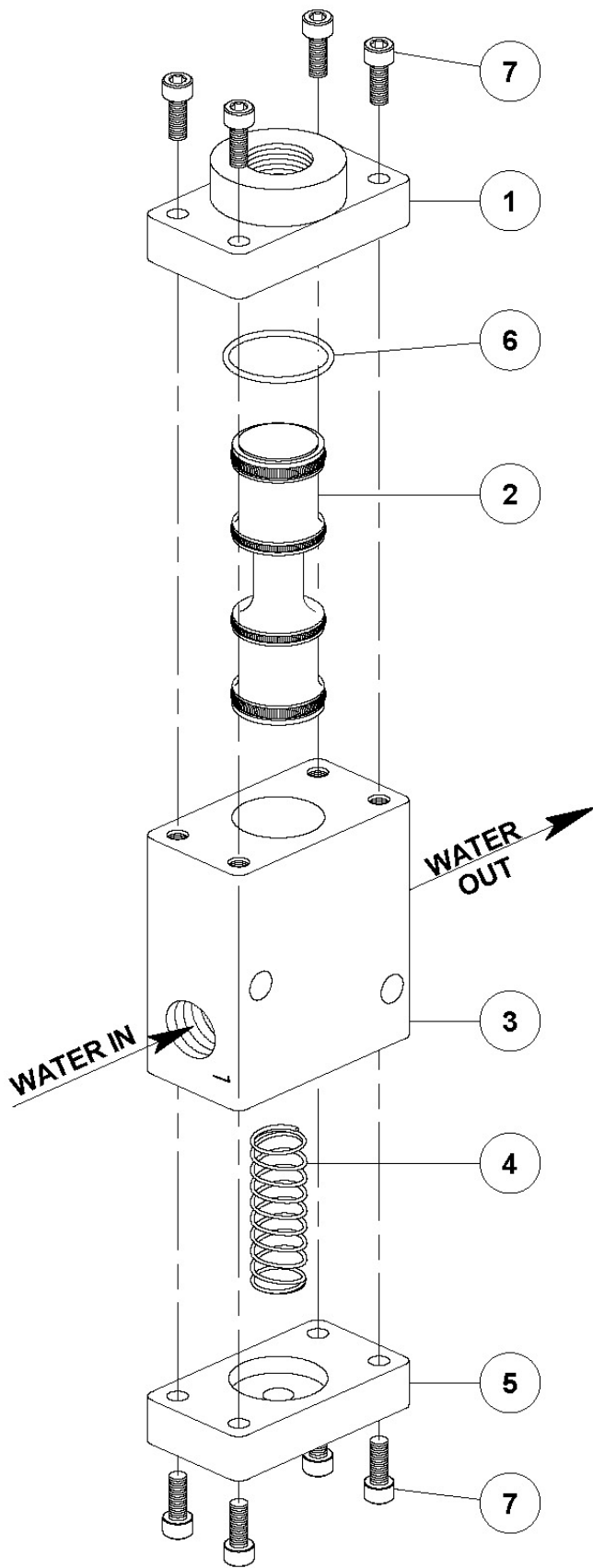

8200-000-09		Water Control Valve
No.	Part No.	Description
8200-000-09R		Replacement Parts Kit
1.	Not Available	Air Operator Cap
2.*	Not Available	Plunger w/O-Rings
3.	Not Available	Valve Body
4.*	Not Available	Spring
5.	Not Available	Spring Retainer
6.*	Not Available	O-Ring (Large)
7.	Not Available	Screw (8)

\* Included In replacement parts kit

## 9.8(a) G2 Pneumatic Deadman

Item	Part No.	Description
	2263-002	G2 Pneumatic Deadman
	2263-002-99	G2 Replacement Parts Kit
1.	2263-002-01	G2 Deadman Lever
2.	2263-002-02	G2 Deadman Body
* 3.	2263-002-03	G2 Deadman Cartridge Assembly
4.	2263-002-04	G2 Deadman Hinge Pin
* 5.	2263-002-05	G2 Deadman Cartridge Set Screw
6.	2263-002-06	G2 Deadman Button
* 7.	2263-002-07	Deadman Spring
* 8.	2263-000-08	Deadman Screw For Button
9.	3031-300-00	Hex Nipple, 1/8" x 1/8" With Ball Seat
10.	3031-302-02	Hex Nipple, 1/4" x 1/4" With Ball Seat
* 11.	2263-002-10	G2 Deadman Dust Plug
* Items included in Replacement Kit		

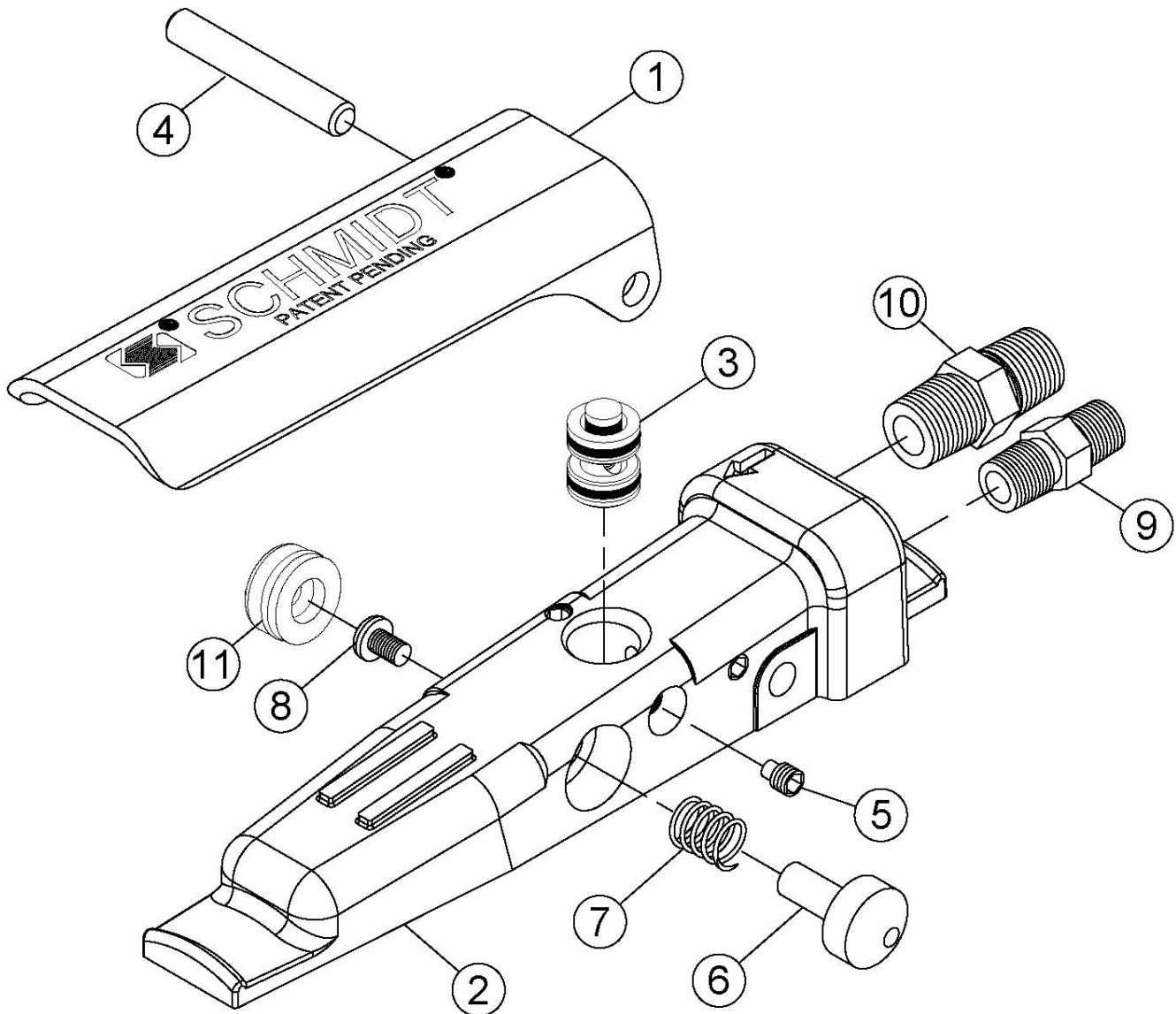



### 9.8(b) Deadman Valves (Pneumatic)

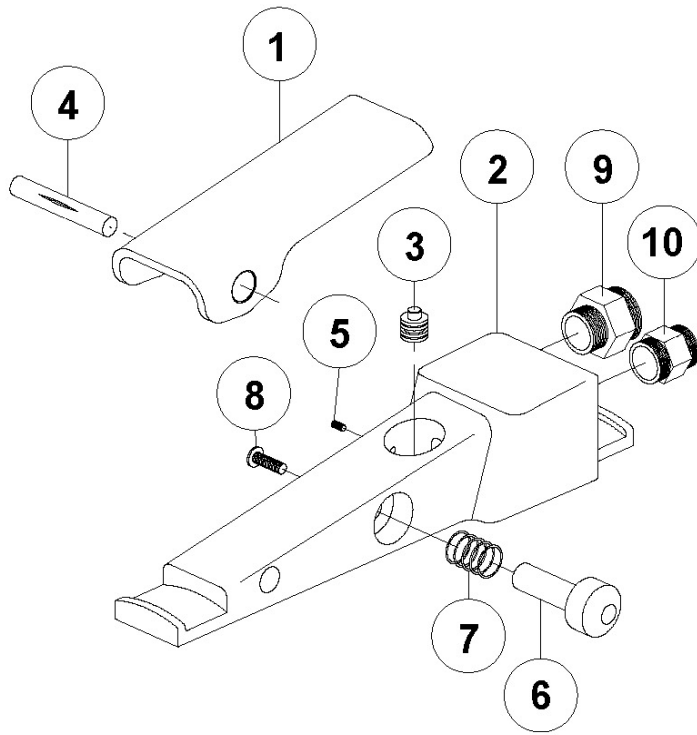

2263-000		Pneumatic Deadman
No.	Part No.	Description
2263-000-99 Replacement Parts Kit		
1.	2263-000-01	Lever
2.	2263-000-02	Body
*3.	2263-000-03	Cartridge
4.	2263-000-04	Hinge Pin
*5.	2263-000-05	Set Screw
6.	2263-000-06	Safety Button
*7.	2263-000-07	Spring
*8.	2263-000-08	Screw for Button
9.	3031-302-00	Hex Nipple, 1/8" x 1/4"
10.	3031-300-00	Hex Nipple, 1/8" x 1/8"
* Included in replacement parts kit		

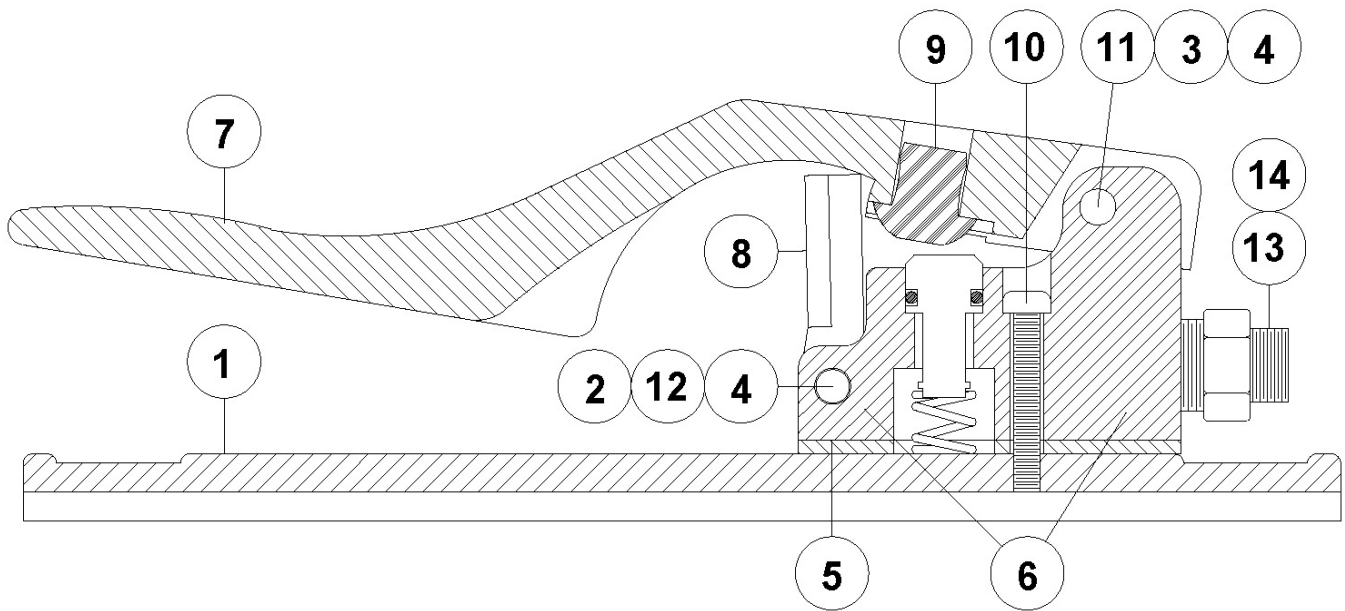

2263-001			Pneumatic Deadman II		
No.	Part No.	Description	No.	Part No.	Description
2263-001-99 Replacement Parts Kit Level I			2263-001-98 Replacement Parts Kit Level II		
1.	2263-001-01	Base	8. +	2263-001-08	Safety Flap
2. +	2263-001-02	Safety Flap Spring	9.**	2263-001-09	Plunger Plug
3. +	2263-001-03	Lever Hinge Screw	10.	2263-001-10	Body Mounting Screw
4.	2263-001-04	Hinge Pin Nut	11.	2263-001-11	Lever Spring
5.**	2263-001-05	Body Gasket	12. +	2263-001-12	Flap Hinge Screw
6.**	2263-001-06	Valve Body Assembly	13.	3031-302-00	Hex Nipple, 1/8" x 1/4"
7.	2263-001-07	Lever	14.	3031-300-00	Hex Nipple, 1/8" x 1/8"
			* Included in replacement parts kit, Level I		
			+ Included in replacement parts kit, Level II		

## 9.9 Deadman Switches (Electric)

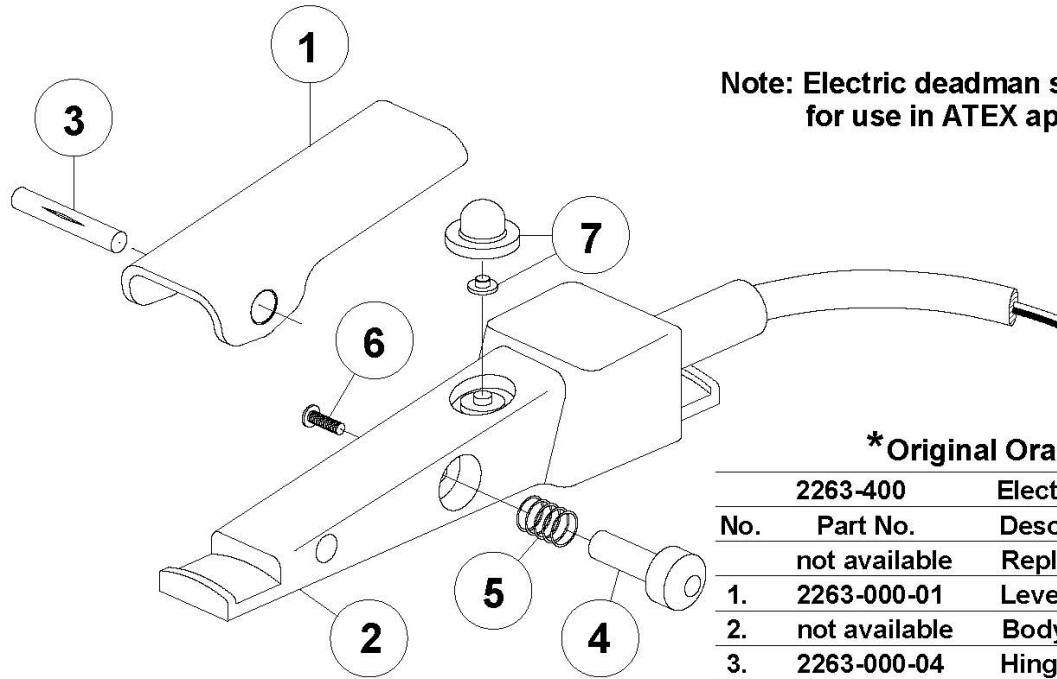

**Note: Electric deadman switches are not for use in ATEX applications.**

### \*Original Orange

No.	Part No.	Description
	2263-400	Electric Deadman
	not available	Replacement Parts Kit
1.	2263-000-01	Lever
2.	not available	Body w/Molded Switch
3.	2263-000-04	Hinge Pin
4.	2263-000-06	Safety Button
5.	2263-000-07	Spring
6.	2263-000-08	Screw for Button
7.	2263-400-09	Dust Cover w/Insert

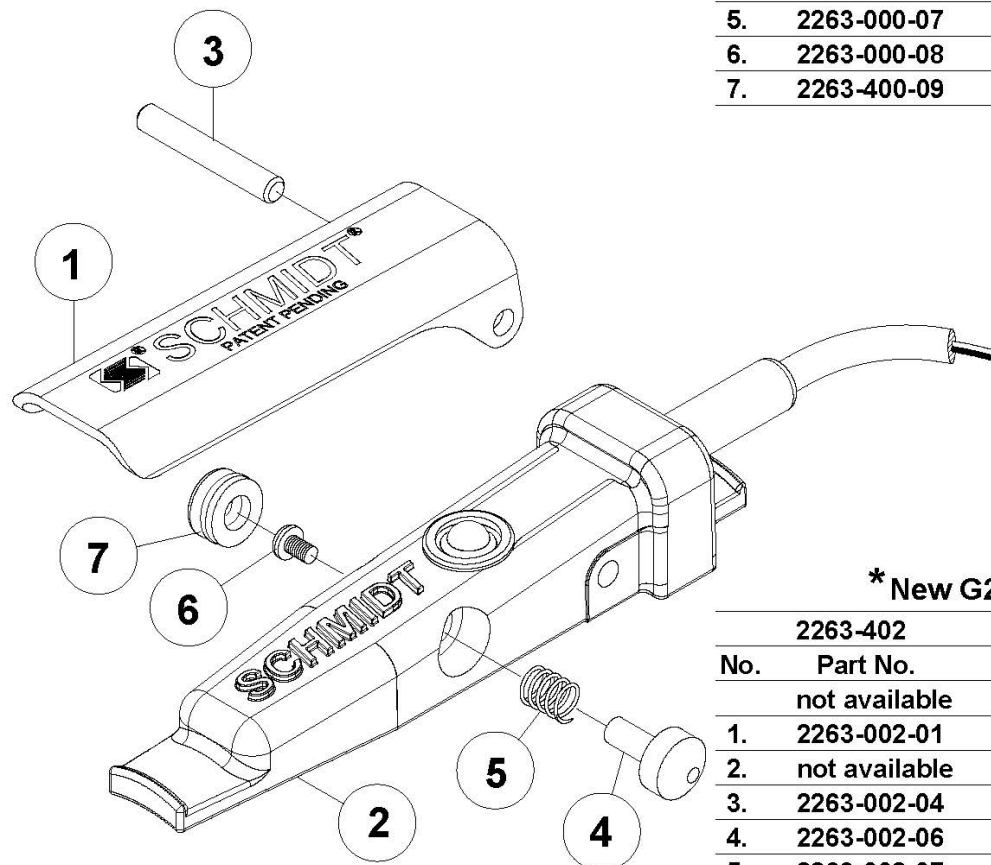

### \*New G2 Electric

No.	Part No.	Description
	2263-402	G2 Electric Deadman
	not available	Replacement Parts Kit
1.	2263-002-01	G2 Lever
2.	not available	G2 Body w/Switch
3.	2263-002-04	G2 Hinge Pin
4.	2263-002-06	G2 Safety Button
5.	2263-002-07	G2 Spring
6.	2263-000-08	Screw for Button
7.	2263-002-10	G2 Dust Plug



\*Electric shock hazard. To minimize shock hazard use electric deadman in low voltage applications only (12-24 volts).

# 9.10

## AmphiBlast™ Dual Port Injection Module

Item	Part No.	Description
	8200-000-78A	Dual Port Injection Module Assembly, 1 1/4"
	8200-000-78	Dual Port Injection Module Assembly, 1 1/2"
1	8200-000-79	Body
2	8200-000-82	Nozzle
3	8200-000-81	Cap Gasket
4	8200-000-83	Nozzle Gasket
5	8200-000-80	Cap
6	8200-000-84	Wash Down Orifice
7	7028-202	Lock Washer 1/4" 18-8SS
8	7010-203-06	Hex Bolt, 1/4" UNC x 1" Lg. 18-8SS
9	8200-000-87	Adapter Flange Gasket
10	8200-000-88	Adapter 1 1/4"
11	8200-000-86	Adapter Flange
12	7010-207-09	Hex Bolt, 3/8" UNC x 2" Lg. 18-8SS
13	7028-203	Lock Washer 3/8" 18-8SS
14	7017-207	Hex Nut, 3/8" UNC 18-8SS
15	4214-309-02	Threaded Coupling, 2" (Full Port)
16	8200-000-78S	Dual Port Injection Module Sub-Assembly

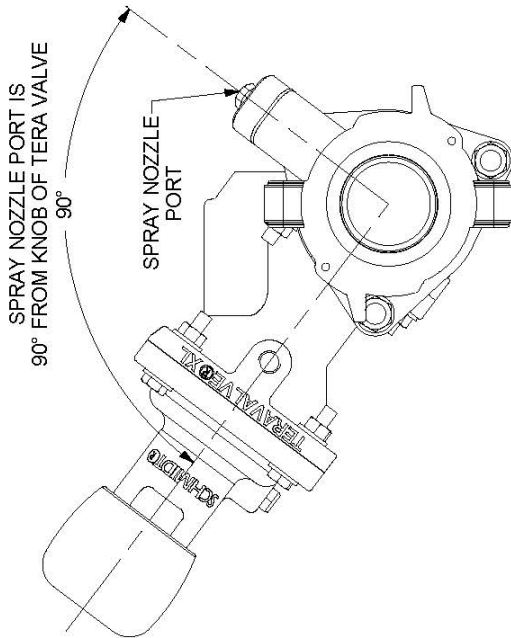

INJECTION MODULE ALIGNMENT DETAIL

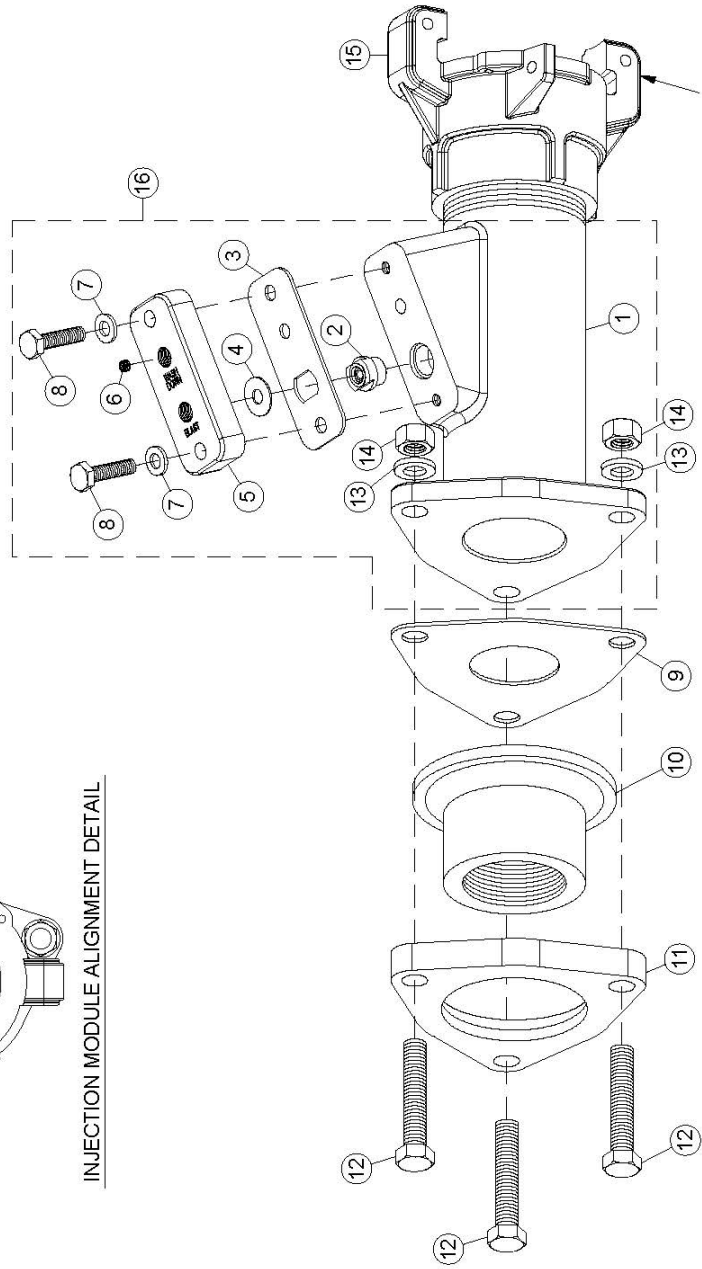

**NOTICE:** REPLACING THE FULL PORT THREADED COUPLING (#15) WITH ANOTHER TYPE WILL RESULT IN EQUIPMENT MALFUNCTION. USE THE CORRECT PART OR THE 1-1/2" X 3' LG. ADAPTER HOSE PROVIDED WITH THE EQUIPMENT. SEE SECTION 5.24

## 9.11 Pop-Up Internal Piping

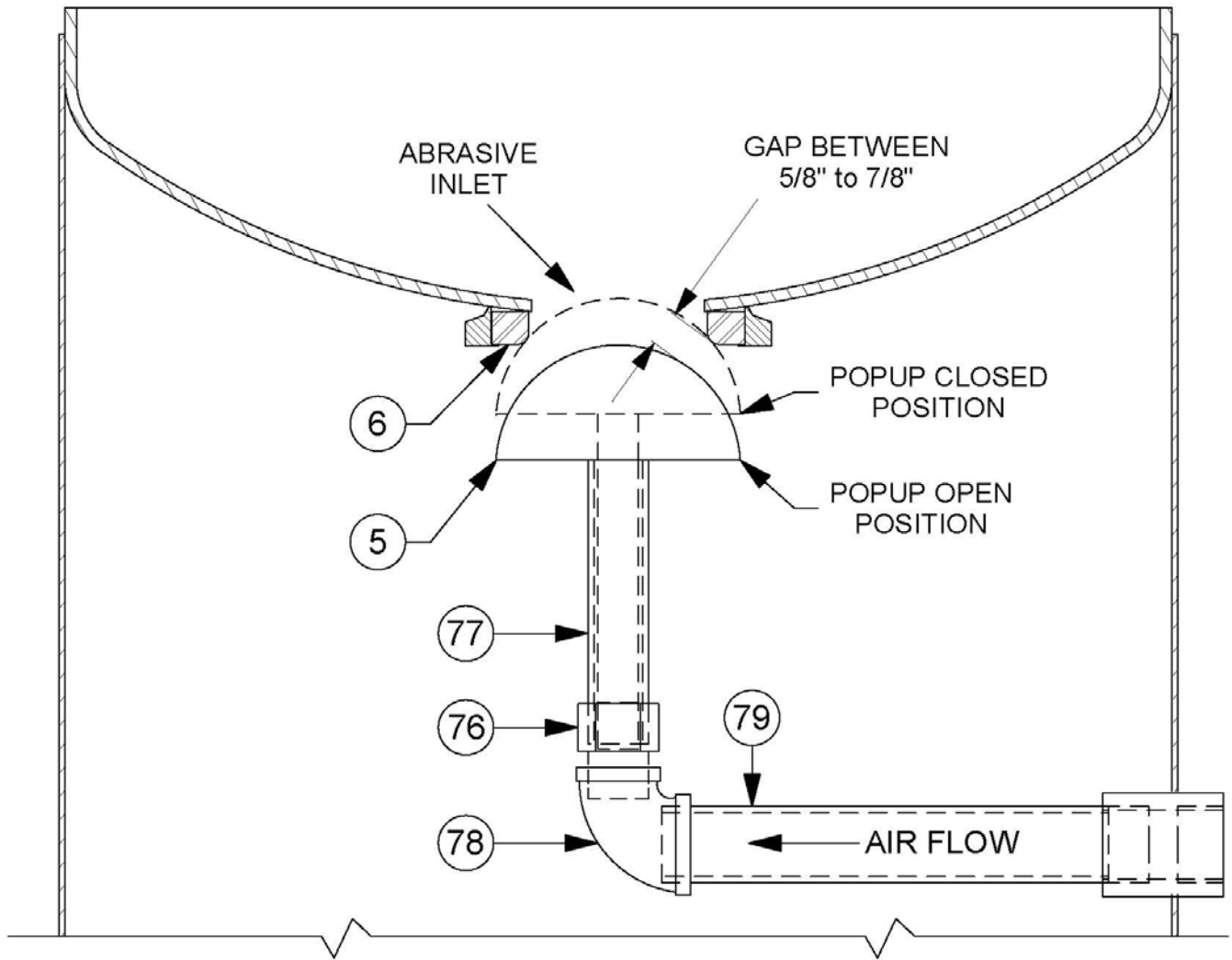

NO.	PART NO.	DESCRIPTION
5.	2100-010	Pop-Up Head
6.	2100-011	Pop-Up Gasket
76.	2497-706	Grit Suppression Valve, 1"
*77.	3030-006-17	Nipple TOE, 1" x 8" LG
78.	3010-007-06	Red. Elbow 90, 1 1/4" x 1"
79.	3029-007-28	Nipple TBE, 1 1/4" x 7 1/2" LG.

\*It may be necessary to cut to length to obtain proper pop-up gap as shown.

## 9.12 Abrasive Spider Adjustment (optional)

ITEM	QTY	PART NO.	DESCRIPTION
1	1	7001-000-98	SPIDER STUDS INSTALLED
2	1	7001-000-02	SPIDER DISK 9"
3	3	7001-000-03	SPIDER SPACER, 1"
4	3	7001-000-04	SPIDER SPACER, 3/4"
5	3	7001-000-05	SPIDER SPACER, 2-1/4"
6	3	7119-002	SAFETY PINS, AIR BLAST HOSE COUPLINGS

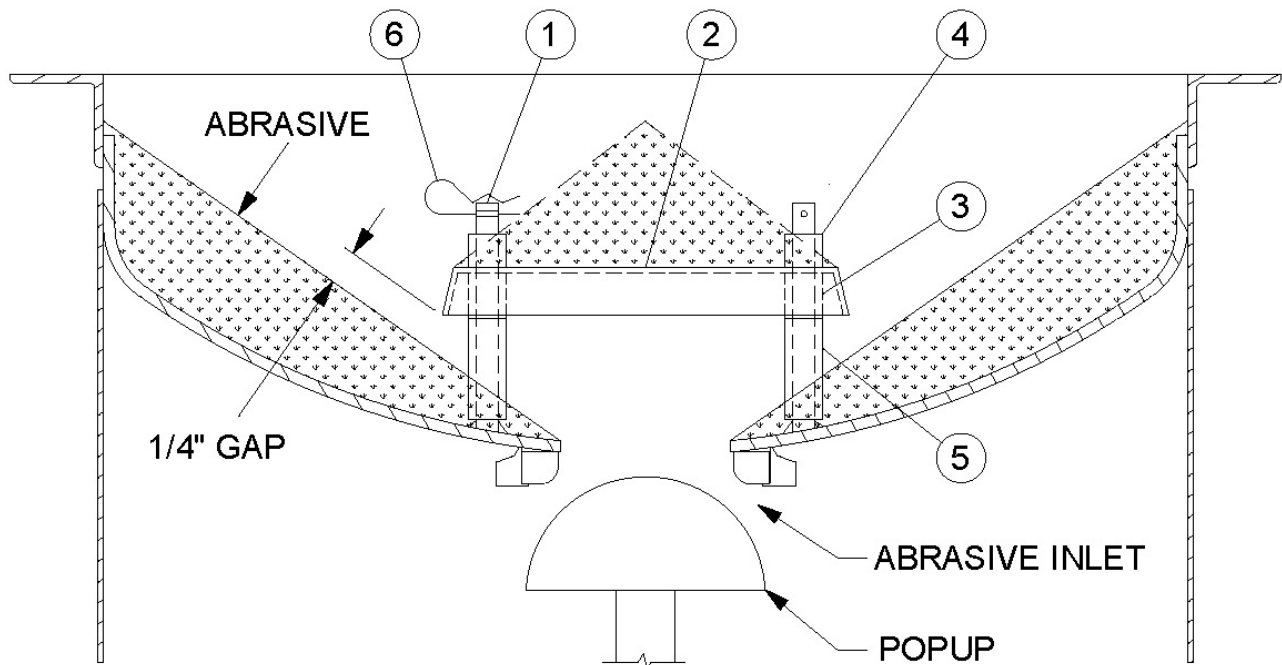

The optional abrasive spider is a device that is mounted in the top head of the abrasive blaster. The spider is installed on blasters that will be installed below an abrasive storage hopper. The spider creates a void area above the blaster abrasive inlet keeping the abrasive from sitting on top of the popup. Abrasive piled on top of the popup restricts movement and can prevent the popup from properly sealing. Pour abrasive into the vessel top head and allow it to flow in and form the areas of dead abrasive above the spider plate and to the sides as shown above. The gap should be approximately 1/4". The spider spacers can be removed to lower the spider disk. The spacers can be cut shorter if necessary.

### **⚠ WARNING**

Pinch point hazard. Vessel pressurization will close the popup. Keep hands and fingers away from popup. Disconnect air supply prior to performing popup maintenance.

## 9.13 Palm/Detent Control Valve

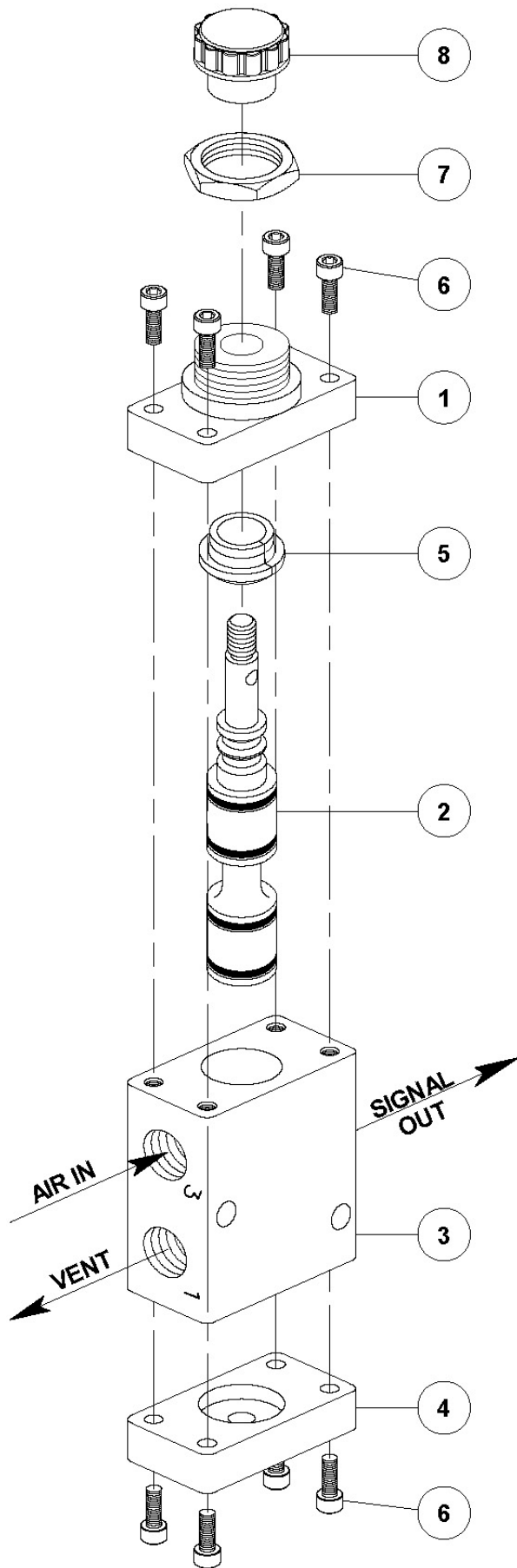

2229-301		Palm/Detent Control Valve
No.	Part No.	Description
	2229-301-99	Replacement Parts Kit
1.	2229-301-01	Operator Cap
2.*	2229-301-02	Plunger w/O-Rings
3.	Not Available	Valve Body
4.	Not Available	Retainer
5.	Not Available	Plunger Bushing
6.	Not Available	Screw (8)
7.	Not Available	Mounting Nut
8.	Not Available	Knob

\* Included In replacement parts kit

## 9.14 Water Tank (Optional)

ITEM	QTY	PART NO.	DESCRIPTION
1	1	2401-502	Ball Valve, 1/4"
2	1	2401-504	Ball Valve, 1/2"
3	1	3000-204	Elbow, 90° 1/2" Stainless Steel
4	1	3006-302	Elbow, Street 90° 1/4" Brass
5	1	3026-204-02	Bushing, 1/2" x 1/4" Stainless Steel
6	1	3026-205-04	Bushing, 3/4" x 1/2" Stainless Steel
7	1	3029-204-99	Nipple, 1/2" x Close Stainless Steel
8	1	3031-312-02	Hex Nipple, 1/4" x 1/4"
9	1.5	4116-004-05	Tubing, Plastic 1/2" White
10	2	4236-304-04	Tube Elbow, 90° 1/2" x 1/2" NPT
11	4	7010-207-07	Hex Bolt, 3/8" UNC x 1 1/4" Stainless Steel
12	2	7010-207-08	Hex Bolt, 3/8" UNC x 1 1/2" Stainless Steel
13	6	7017-207	Hex Nut, 3/8" UNC Stainless Steel
14	12	7027-203-01	Flat Washer, 3/8" STD Stainless Steel
15	6	7028-203	Lock Washer, 3/8" Stainless Steel
16	2	8031-000-42	BRS Reclaimer Screen Knob
17	1	8200-000-110	Amphiblast Water Tank, 15 Gallon
18	1	8200-000-112	Water Tank Fill Port w/ Cap

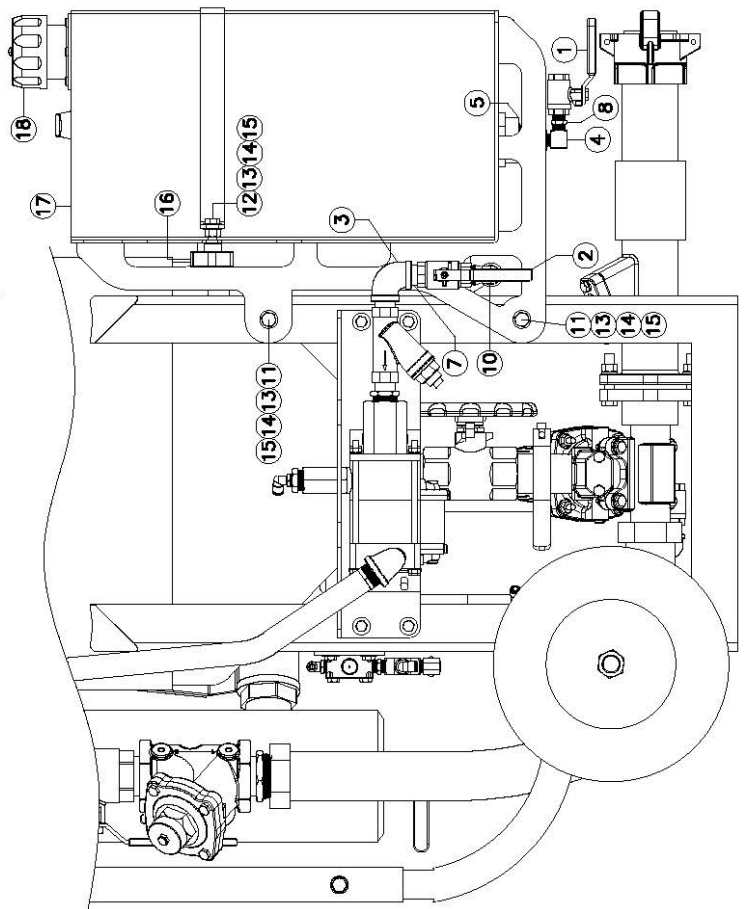
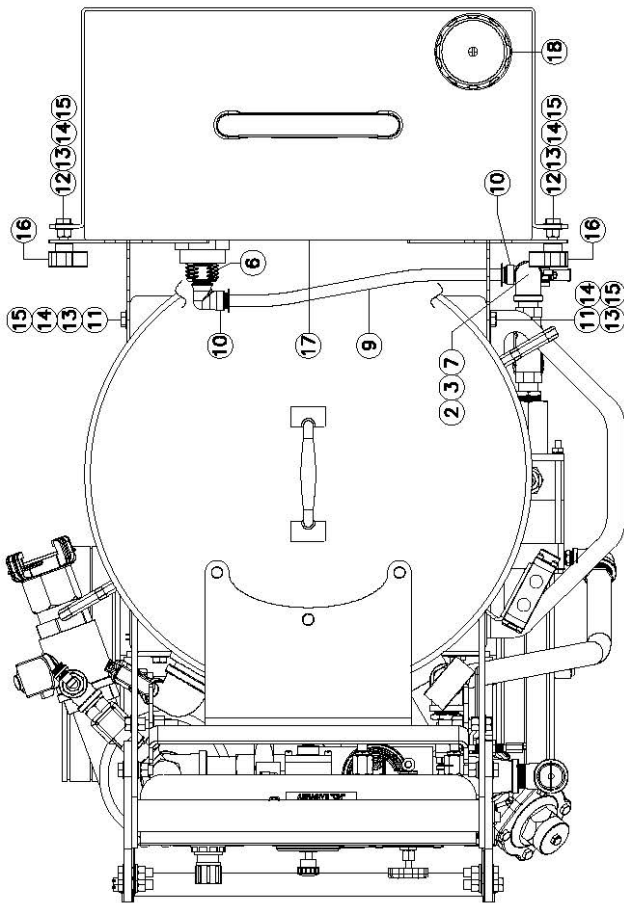

## 10.0 Recommended Spare Replacement Parts Lists

### A) ELECTRIC and PNEUMATIC CONTROLS (see note below & refer to Section 9.0 drawings)

Item No.	Qty.	Part No.	Description
2	1	4211-10X	Air Inlet Crowfoot (specify piping size)
2	10	4211-999	Crowfoot Gasket (specify piping size)
3	1	2401-50X	Air Inlet Ball Valve (specify piping size)
4	1	2401-502	Blowdown Ball Valve, 1/4"
5	1	2100-010-04	Popup With Stem
6	1	2100-011	Popup Gasket
8	1	2401-502	Drain Ball Valve, 1/4"
9	1	2123-10X	Auto Air Valve (specify piping size)
9	1	2123-00X-02	Auto Air Valve Diaphragm (specify size)
9	5	2123-00X-21	Auto Air Valve Disc (specify size)
9	1	2123-10X-24	Auto Air Valve Spring (specify size)
9	1	2123-00X-99	Auto Air Valve Replacement Parts Kit (specify size)
10	1	4104-40X-XX	Blast Hose Assembly (specify size and length)
11	1	500X-XXX	Blast Nozzle (specify size and type)
13	1	2401-50X	Choke Ball Valve (specify piping size)
14	1	2130-00XD	Tera Valve™ (specify piping size)
14	1	2130-000-03	Tera Valve Spring
14	1	2130-00X-12	Tera Valve Base (specify piping size)
14	1	2130-000-98D	Tera Valve Replacement Part Seals Kit
14	1	2130-000-99D	Tera Valve Replacement Part Kit
21	1	2014-300	Breather Vent, 1/8"
22	1	7000-001-11	Handway Crab Assembly, 6" x 8"
23	1	2301-904-90	Strainer, 1/2" (90 micron)
25	2	4215-XXX	Nozzle Holder (specify size and type)
26	2	4213-408-01	Blast Hose Coupling, 1-1/2" (full port) See Section 5.12
27	2	4214-408-02	Threaded Coupling, 1-1/2" (full port) See Section 5.24
27	10	4214-999-02	Coupling Gasket (full port) (fits hose and threaded couplings)
28	1	2000-010-99	Slave Regulator Replacement Parts Kit
32	1	8200-000-78A	Dual Port Injection Module, 1-1/4"
	1	8200-000-78	Dual Port Injection Module, 1-1/2"
34	2	7000-001-18	Handway Gasket, 6" x 8" (SureFit™)
35	1	2013-402	Dust Eliminator, 1/4"
36	2	4205-10X	Hose Insert (specify size)
36	10	4205-10X-99	Insert Gasket (specify size)
37	2	4235-00X	Hose Clamp, Double Bolt (for field installation) (specify size)
38	10ft	4102-00X	Air Hose (specify size)
39	20	7119-002	Safety Pin, Air/Blast Hose Coupling
39	10	4214-999	Coupling Gasket
40	2	8710-98778	Hose Whip Check
44	1	2001-011-99	Blast Pressure Regulator Replacement Parts Kit
45	1	8710-40007A	Pressure Gauge 0-160 psi
46	1	8200-000-26	Wash down Pressure Regulator 0-100 psi
48	1	2229-301-99	Palm Button Control Valve Replacement Parts Kit
50	1	2006-002-99	Water Differential Pressure Regulator Replacement Parts Kit
52	1	8200-000-09	Water Control Valve
54	1	2401-907	Abrasive Shut-Off Valve See Section 5.15
54	10	8710-98503	Tri-Clamp O-ring
58	1	2210-002-97	Water Pump Air Drive Seal Kit
58	1	2210-002-98	Water Pump Fluid Section Seal Kit

### B) ITEMS FOR PNEUMATIC CONTROLS ONLY (see note below)

12	1	2263-XXX	Pneumatic Deadman Valve (specify type)
12	2	2263-XXX-99	Pneumatic Deadman Valve Replacement Parts Kit (specify type)
15	1	4100-501	Twinline Hose, 55ft.
16,19	1	4224-301-02	Quick Disconnect Socket, 1/4"
17,18	1	4224-300-02	Quick Disconnect Plug, 1/4"
20	1	2229-000	Pneumatic Control Valve
20	1	2229-000-99	Pneumatic Control Valve Replacement Parts Kit
-	-	-	-

### C) ITEMS FOR ELECTRIC CONTROLS ONLY (see note below)

12	1	2263-402-05	Electric Deadman Switch With Plug (sealed connector)
15	1	7074-055-03	Extension Cord With ACO 55' (sealed connectors)
16,19	1	7109-300-02	Sealed Electric Connector, 3-Prong Female
17,18	1	7109-301-02	Sealed Electric Plug, 3-Prong Male
20	1	2229-100	Electric Control Valve, 12Vdc
20	1	2229-100-99	Electric Control Valve Replacement Parts Kit
-	-	-	-

**NOTE:** Determine the type of blast controls on the abrasive blaster (either electric or pneumatic). Then, the required list of spare parts is List "A" plus either List "B" or "C". For blasters with special options refer to supplemental drawing(s) included with this operation and maintenance manual.



## 11.0 Troubleshooting

This section lists probable causes of problems that may occur during operation of the abrasive blaster. Not all of the “probable causes” may apply to your particular abrasive blaster. The probable cause may not apply because of the control type and accessories on the abrasive blaster. Refer to Figure 11.1 and the drawings in Section 9.0.

### DANGER

Abrasive blasters are Pressurized Vessels. Propelled objects will cause serious injury or death. Depressurize vessel before performing any maintenance. See Section 6.2.

## 11.1 Malfunction With Deadman Lever In The “Off” Position

### 11.1.1. Blast air stops but abrasive will not shut off

- (1) Trash stuck between plunger and seat in Tera Valve™ (#14) prevents closing.
- (2) Defective valve plunger in Tera Valve (worn by abrasive or broken).
- (3) Defective sleeve in Tera Valve (worn by abrasive).
- (4) Blocked signal air hose to Tera Valve (trash blockage or pinched hose).
- (5) Defective or broken spring in Tera Valve (check length of spring).
- (6) Tera Valve cap (or spring retainer) not screwed all the way down (hand tighten only).

### 11.1.2. Abrasive stops but blast air will not shut off

- (1) Defective or broken spring in automatic air valve (#9).
- (2) Defective seat in automatic air valve.
- (3) Blocked signal air hose to automatic air valve.
- (4) Defective o-ring in automatic air valve (around shaft).

### 11.1.3. Both blast air and abrasive will not shut off

- (1) Twinline hoses to deadman valve (#12) are crossed.
- (2) Non-Schmidt deadman (#12) has been installed.
- (3) Control valve (#20) stuck in the “ON” position.
- (4) Blocked twinline hose.
- (5) Defective deadman valve (#12). Pneumatic deadman cartridge plunger stuck in the “ON” position (down). Cartridge plunger is visible below deadman handle.
- (6) Control valve (#20) stuck in the “ON” position.

### 11.1.4. Blast outlet turns on accidentally

- (1) The deadman lever (#12) is worn out.
- (2) The safety button on the deadman is missing. See drawings in Sections 9.8 and 9.9.
- (3) A bleeder type deadman valve has been installed. A bleeder type deadman valve *is not safe* because a particle of dirt from the air hose can plug the bleed hole and cause the blast outlet to turn on. See *Warnings* and *Rules for Safer Operation* in Section 1.0.
- (4) Defective electric deadman switch or electric wiring (check for an electric short).

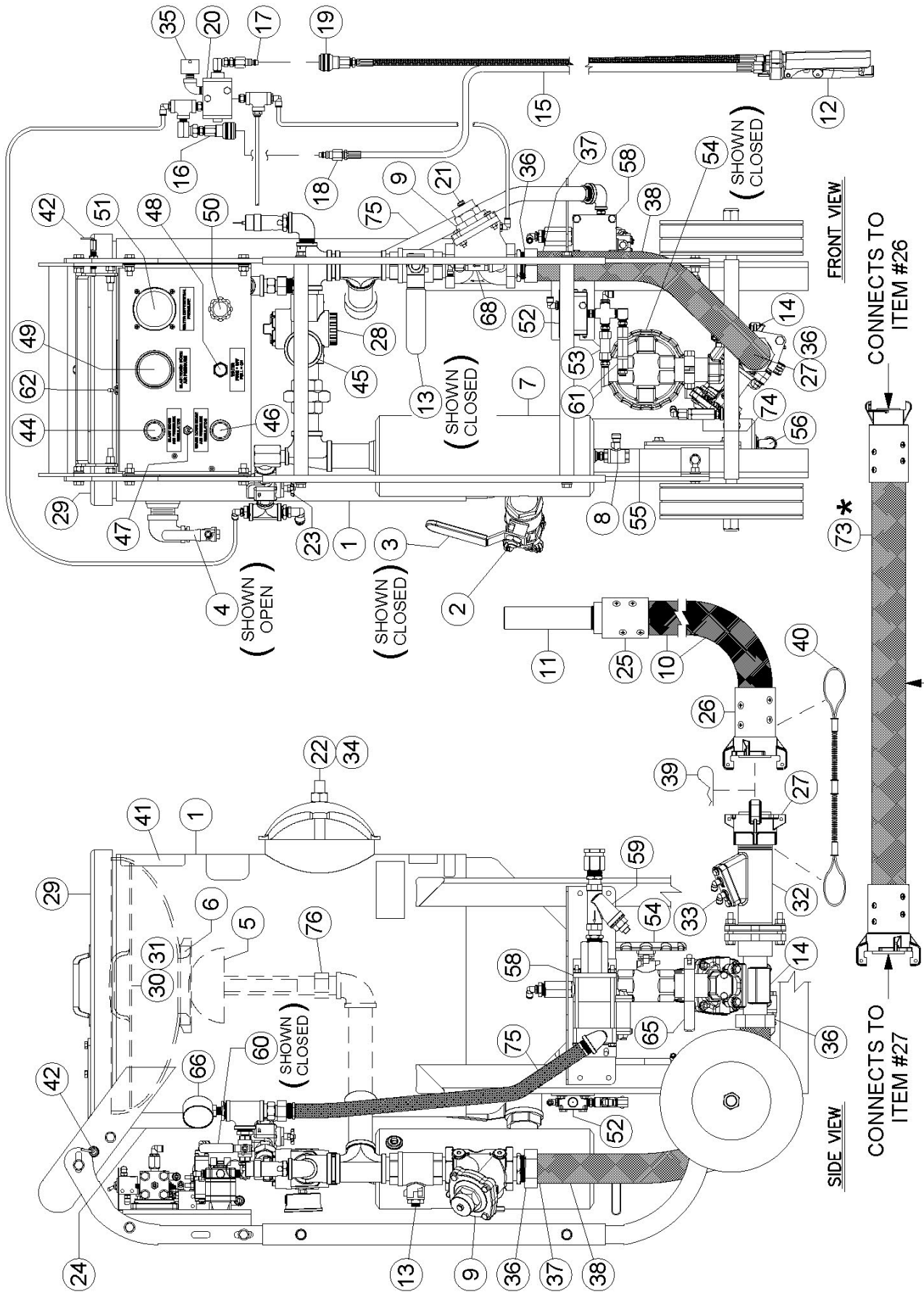

Figure 11.1 – AmphiBlast™ With Pneumatic Blast Controls

## 11.2 Malfunction With Deadman Lever In The “On” Position

### 11.2.1. Air blasts with no abrasive

- (1) Check abrasive level in blast vessel (even if optional second outlet blasts normally).
- (2) Blocked control air hose to Tera Valve™ (#14) prevents opening.
- (3) Tera Valve (#14) plunger stuck in closed position.
- (4) Trash plugging opening from tank to Tera Valve (#14). See Section 11.3.
- (5) Insufficient air pressure to open Tera Valve (fully open requires 80 psig).
- (6) Abrasive flow problems. See Section 11.3.
- (7) Defective Tera Valve piston seal (air will leak from breather).
- (8) Blast vessel leak (popup or handway) reduces pressure slowing abrasive flow.
- (9) Control valve (#20) stuck in exhaust position or midway (air will leak from breather #35).
- (10) Defective abrasive cutoff valve or switch (#62).
- (11) Tera Valve (#14) outlet clogged with wet abrasive because full port threaded coupling (#27) is not installed on outlet of injection module (#32). See Section 5.24.

### 11.2.2. Abrasive choking out of blast hose with low blast air pressure

- (1) Tera Valve (#14) abrasive adjustment knob is open too far.
- (2) Control air hose to automatic air valve (#9) blocked, pinched, or leaking prevents opening.
- (3) Choke valve (#13) is partially closed causes differential pressure increases abrasive flow.
- (4) Low air compressor output cfm (unit may cycle on and off). See Section 3.0.
- (5) Blocked automatic air valve (#9) breather vent (#21) prevents full opening.
- (6) Control valve (#20) stuck in exhaust position or midway (air will leak from breather #35).

### 11.2.3. Reduced Pressure At The Nozzle (with or without abrasive flow)

- (1) Low air compressor output CFM. See Section 3.0 to determine air requirements.
- (2) Air supply hose to blaster is too small. See Section 3.0.
- (3) Tera Valve abrasive adjustment knob (#14) is open too far.
- (4) Check for leaks in blast vessel (popup or handway) or control piping.
- (5) Choke valve (#13) is partially closed.
- (6) Blocked automatic air valve (#9) breather vent (#21) prevents full opening.
- (7) Trash blocking the blast nozzle orifice (#11). Release deadman and allow the air pressure in the blast hose (#10) to dissipate. Close the air inlet ball valve (#3). **Note:** Only after the air in the blast hose has dissipated then remove the blast nozzle (#11) and clear blockage.



Confirm the air in the blast hose has dissipated before removing the blast nozzle. Squeeze or step on the blast hose. Firmness or stiffness indicates that the blast hose is pressurized. Do Not attempt to remove the blast nozzle. Allow the air to dissipate before proceeding.



Do Not aim the blast nozzle towards yourself or any person. A system malfunction or a blocked blast nozzle that clears can trigger accidental start up resulting in injury to personnel.

### 11.2.4. Blast is slow to turn on or will not turn on when deadman lever is pressed down.

- (1) Check quick couplings (#16, #17, #18, & #19) on control hoses to see if they are connected properly.
- (2) Control valve (#20) stuck in exhaust position or midway (air will leak from breather #35).
- (3) 1/2" air filter/strainer (#23) blocked; restricts air flow to deadman.
- (4) Twinline control hoses (#15) are blocked.
- (5) Cartridge in deadman valve (#12) is blocked.
- (6) Low air compressor output CFM (unit may cycle on and off). See Section 3.0.
- (7) Air leaks in twinline hose (#15) from the deadman valve (#12) to control valve (#20).
- (8) Trash blocking the blast nozzle orifice (#11). See Item (7) in Section 11.2.3 above.
- (9) Blocked automatic air valve (#9) breather vent (#21) prevents full opening.

### 11.2.5. Air and abrasive blasts with no or inconsistent water

- (1) Water differential pressure (#51) is too low.
- (2) Low water level in water tank (pump will cycle continuously).
- (3) Water tank outlet ball valve is closed (pump will cycle continuously).
- (4) Hose from water tank to water pump (#58) is blocked (pump will cycle continuously).
- (5) Y-strainer (#59) screen is clogged (pump will cycle continuously).
- (6) Air supply hose to water pump (#58) is blocked (pump will not be cycling).
- (7) Water control valve (#52) is stuck in “OFF” position.
- (8) Water pump malfunction. Refer manufacturer’s manual troubleshoot in Section 14.0.
- (9) Insufficient air supply to unit (inconsistent water). See Section 5.19.

## 11.3 Notes on Abrasive Flow Problems

### 11.3.1. Tera Valve™ operation

If abrasive flow is a problem, remember; the Tera Valve (#14) only opens and closes. The total travel to full open is approximately 3/4 of an inch. This can be quickly checked with the adjustment knob on the abrasive valve.

For this procedure manually close the choke valve (#13) and the abrasive shut-off union end ball valve (if so equipped) to stop blast flow. This test is to verify that the Tera Valve is opening.

With the deadman (#12) off, screw the Tera Valve (#14) knob down until it stops. Notice that the knob turns easily when the deadman is off. Next, back the knob out 3/4 of an inch or slightly less, then press the deadman lever down to open the Tera Valve. The knob should get tight or more difficult to turn because the valve has opened against the adjustment. This guarantees that the valve is fully open. If the material will not flow with the valve fully open, you have an abrasive flow problem, not a problem with the Tera Valve. The abrasive may be wet, or there may be trash blocking the opening. Try choking the blast outlet to clear the opening. Proceed to step 11.3.2. If the knob does not get tighter during this test troubleshoot the controls and the Tera Valve piston seal.



Do Not hammer on any part of the pressure vessel to improve abrasive flow. This can cause cracks that may lead to pressure vessel rupture.

### 11.3.2. Choking the blast outlet

The choke valve (#13) is used to clear any trash that may get into the blast vessel and block the Tera abrasive valve orifice. Whenever trash (paint chip, cigarette butt, etc.) blocks the abrasive valve orifice, the procedure is to fully open the valve by turning the knob counterclockwise, then press down the deadman lever (#12) to begin blasting. While blasting, have an assistant close the choke valve completely for about one second. This creates differential pressure at the abrasive valve (high pressure above; low pressure below). The higher pressure from the blast vessel should be enough to loosen the trash blocking the abrasive valve orifice and blast it through the blast nozzle (#11). To minimize excess wear of the Tera Valve keep the choke valve fully open during normal blasting. If the blaster is equipped with the abrasive cutoff feature set the valve (or switch) to the on-position for the choke procedure.

**Note:** Trash cleared during the choking process may block the nozzle orifice. Refer to Item (7) in Section 11.2.3 for procedure to clear nozzle.

**Note:** The Tera Valve include a cleanout port to use for this procedure. See the valve drawings in Section 9.4 (Item 13).

### 11.3.3. **Blast control hoses**

Remember, the blaster controls and valves are normally closed. Therefore, the control hoses are depressurized to turn the blast off and pressurized to turn the blast on. If a needle gauge is available, it is the quickest way to check to see if there is pressure in the control hoses. If no needle gauge is available, disconnect each control hose fitting one at a time until the problem is located.

### 11.3.4. **Contaminated Abrasive**

Air quality is crucial to the operation of an abrasive blaster. Moisture and contaminants can cause components to malfunction. Moisture condensation in a blast system causes abrasive flow problems. Condensation occurs when the hot vapor-filled compressed air cools as it reaches the abrasive blaster. Water droplets formed during condensation can be absorbed by the abrasive in the blast vessel which can cause erratic flow to the abrasive valve. To minimize the chance of abrasive flow problems a moisture removal device installed for the blast system air supply is highly recommended (i.e. coalescing moisture separator, air-cooled aftercooler or deliquescent dryer). Contact a local authorized Schmidt® distributor or Axxiom Manufacturing, Inc. to locate one near you.



Do Not hammer on any part of the pressure vessel to improve abrasive flow. This can cause cracks that may lead to pressure vessel rupture.

### 11.3.5. **Recycled Abrasives**

Used & recycled abrasives can contain trash & coating particles removed from previously blasted items (particularly sticky coatings) that can cause abrasive to clump together and block the metering valve orifice and stop flow. Prior to use recycled abrasive must be passed through a screen with openings no larger than 1/4" round. Some applications may require smaller openings. Refer to Section 11.3.4

Trash in recycled abrasive can also prevent the abrasive valve plunger from properly seat. The result will be air leakage at the blast nozzle in the off mode. This leak will gradually worsen due to the blasting effect of the leak. This leak will cause premature wear of the seat, plunger, and sleeve.



Recycled abrasive can contain trash that can cause equipment malfunction. Prior to use, recycled abrasive must be passed through a screen with openings no larger than 1/4" round. Some applications may require smaller openings.

## 12.0 Warranty and Reference Information

### 12.1 Warranty

This following section is to be used as a guide in determining warranty policies and procedures for SCHMIDT® products. It is to be used in determining whether a warranty is justified and as a procedural guide in completing a SCHMIDT warranty claim.

### 12.2 Warranty Policy

1. All SCHMIDT products are guaranteed to be free of defects in material and workmanship at time of shipment. Axxiom Manufacturing, Inc. warrants its products against defects in material and workmanship under normal and proper use for a period of ninety (90) days from the date of delivery. Such warranty is extended only to the buyer who purchases the equipment directly from Axxiom Manufacturing, Inc. or its authorized distributors. This warranty does not include expendable parts such as, but not limited to, hoses, nozzles, and seals.
2. The obligation under this warranty is strictly limited to the replacement or repair, at Axxiom's option, of machines and does not include the cost of transportation, loss of operating time, or normal maintenance services. Axxiom Manufacturing, Inc. shall have no liability for labor, consequential damages, freight or special charges.
3. This warranty does not apply to failure occurring due to abuse, misuse, negligence, corrosion, erosion, normal wear and tear, alterations or modifications made to the machine without express written consent of Axxiom Manufacturing, Inc.
4. Warranty requests must be submitted in writing within thirty (30) days after failure.
5. Written authorization to return merchandise under warranty must first be obtained from Axxiom Manufacturing, Inc. In no case is merchandise to be returned to Axxiom for credit without authorization. At the time of authorization, Axxiom will issue a return authorization number that must be included on all packages and correspondence. Any material returned without prior authorization will remain the property of the sender and Axxiom will not be responsible for it.
6. All returns must be shipped prepaid freight. All returns may be exchanged for other equipment or parts of equal dollar value. If goods are not exchanged, they are subject to a 20% restocking charge. Any cost incurred by Axxiom Manufacturing, Inc. to restore such goods to first class condition will be charged to the customer.
7. Axxiom Manufacturing, Inc. reserves the right to inspect and make the final decision on any merchandise returned under warranty.
8. Axxiom Manufacturing, Inc. offers no warranty with respect to accessories, including but not limited to, engines, motors, batteries, tires and any other parts not manufactured by Axxiom Manufacturing, Inc., but which the original manufacturer warrants.

9. Axxiom Manufacturing, Inc. reserves the right to make product changes or improvements without prior notice and without imposing any obligation upon itself to install the same on its products previously sold.
10. The above warranty conditions can only be altered by Axxiom Manufacturing, Inc. Axxiom must confirm alterations in writing for each specific transaction.
11. Axxiom Manufacturing, Inc. reserves the right to establish specific warranty terms for used or demo machines on an individual transaction basis. Invoices covering such merchandise will clearly state the provisions of the applicable warranty for each specific transaction.
12. USE OF NON-ORIGINAL SCHMIDT® FACTORY REPLACEMENT PARTS ON ANY SCHMIDT EQUIPMENT VOIDS ALL WARRANTIES.
13. AXXIOM MANUFACTURING, INC. DOES NOT AUTHORIZE ANY PERSON, REPRESENTATIVE OR SERVICE OR SALES ORGANIZATION TO MAKE ANY OTHER WARRANTY OR TO ASSUME ON BEHALF OF AXXIOM MANUFACTURING, INC. ANY LIABILITY IN CONNECTION WITH THE SALE OF OUR PRODUCTS OTHER THAN THOSE CONTAINED HEREIN.
14. UNDER NO CIRCUMSTANCES SHALL AXXIOM MANUFACTURING, INC. BE LIABLE TO CUSTOMER OR ANY OTHER PERSON FOR ANY DIRECT, INCIDENTAL, OR CONSEQUENTIAL DAMAGES RESULTING FROM THE USE OF THE PRODUCT OR ARISING OUT OF ANY BREACH OF ANY WARRANTY OR FOR ANY SPECIAL OR CONSEQUENTIAL DAMAGES OF ANY CHARACTER, INCLUDING WITHOUT LIMITATIONS, DAMAGES FOR ANY LOSS OF GOODWILL, WORK STOPPAGE, OR ANY AND ALL OTHER COMMERCIAL DAMAGES OR LOSSES.
15. AXXIOM MANUFACTURING, INC. MAKES NO OTHER WARRANTIES, EXPRESSED OR IMPLIED, INCLUDING, BUT NOT LIMITED TO, THE IMPLIED WARRANTIES OF MERCHANTABILITY AND FITNESS FOR A PARTICULAR PURPOSE WITH RESPECT TO THE SCHMIDT PRODUCTS SOLD PURSUANT THERETO.

### **12.3 Trademarks, Patents, and Proprietary Statements**

Schmidt®, the Schmidt stylized “S” logo, Thompson®, Microvalve®, MV2®, TeraValve™, and Combovalve® are registered trademarks owned by Axxiom Manufacturing, Inc. Use of Schmidt, the Schmidt stylized “S” logo, Thompson, Microvalve, MV2, Tera Valve, and Combovalve trademarks without the written consent of Axxiom Manufacturing is strictly prohibited.

Products manufactured and marketed by Axxiom Manufacturing, Inc. are protected by patents issued or pending in the United States and other countries.

The text, diagrams, and drawings contained in this manual are proprietary information intended solely for instruction in the operation of the specified equipment. Use of any text, diagrams, or drawings contained in this manual for any reason other than its intended purpose without the written consent of Axxiom Manufacturing, Inc. is strictly prohibited.

## 12.4 Safety Information Sources

### ***Axxiom Manufacturing, Inc***

This equipment and all Schmidt® equipment are manufactured exclusively by Axxiom Manufacturing, Inc. If any operational or safety related questions arise relating to this equipment contact Axxiom Manufacturing, Inc.

Phone: 1-800-231-2085

Website: [www.SchmidtAbrasiveBlasting.com](http://www.SchmidtAbrasiveBlasting.com)

Axxiom Manufacturing, Inc.

11927 South Highway 6

Fresno, Texas 77459

***Occupational Safety and Health Administration (OSHA)*** establishes and enforces regulations regarding safety practices in the workplace including the abrasive blasting industry. Any questions, reporting of work related injuries, or reporting of unsafe work practices can be made to the following contact information. Answers to most any safety related questions can be found at the OSHA website shown below.

Phone: 1-800-321-6742

Website: [www.osha.gov](http://www.osha.gov)

U.S. Department of Labor

Occupational Safety and Health Administration

200 Constitution Avenue

Washington D.C. 20210

***National Institute of Occupational Safety and Health (NIOSH)*** is a federal agency responsible for conducting research and recommendations for the prevention of work related injuries and sickness.

Phone: 1-800-356-4674

Website: [www.cdc.gov/niosh](http://www.cdc.gov/niosh)

National Institute of Occupational Safety and Health

Hubert H. Humphrey Bldg.

200 Independence Avenue, SW

Room 715H

Washington, DC 20201

***American National Standards Institute (ANSI)*** coordinates the development and use of voluntary consensus standards including safety standards.

Phone: 1-202-293-8020

Website: [www.ansi.org](http://www.ansi.org)

American National Standards Institute

1819 L Street, NW

6<sup>th</sup> Floor

Washington, DC 20036



## 12.5 Surface Preparation Information Sources

*The Society for Protective Coatings (SSPC)* consists of research and testing committees, conducts seminars and establishes industry standards on surface preparation methods, abrasive and coatings.

Phone: 1-412-281-2331  
 Website: [www.sspc.org](http://www.sspc.org)

The Society for Protective Coatings  
 40 24th Street  
 Pittsburg, PA 15222-4643

*National Association of Corrosion Engineers (NACE)* develops test methods and recommended practices on surface preparation techniques and coatings.

Phone: 1-281-228-6200  
 Website: [www.nace.org](http://www.nace.org)

National Association of Corrosion Engineers  
 1440 South Creek Drive  
 Houston, TX 77084

## 12.6 Table of Blast Abrasive Characteristics

Abrasive Type	Hardness (Mohs)	Grain Shape	Density Lbs/ft <sup>3</sup>	Color	Free Silica Content	No. of Recycles	Initial Cost	Typical Use
Corn Cobs	2	angular	35-45	tan	none	4-5	low	stripping paint from delicate substrates
Sodium Bicarbonate	2.8	crystal	60	white	none	4-5	medium	cleaning and stripping paint from delicate substrates
Walnut Shell	3	angular	45	lt. brown	none	4.5	low	stripping paint from delicate substrates
Plastic	3.2	angular	45-60	white	none	8-10	medium	Paint stripping, deburring, and cleaning
Glass Beads	4.5	spherical	90	crystal	none	8-10	low	cleaning finishing
Starblast XL	6.5	spherical	128	lt. brown	<1%	4-5	medium	outdoor blasting
Coal Slag	7	angular	85	black	none	1-2	medium	outdoor blasting
Copper Slag	7	angular	112	black	none	1-2	medium	outdoor blasting
Garnet	7	angular	147	pink	<2%	4-5	medium	outdoor blasting
Steel Shot	8	spherical	280	steel grey	none	200	low	cleaning and peening
Steel Grit	8	angular	280	steel grey	none	200	medium	removing heavy scale
Aluminum Oxide	9	angular	120	brown	<1%	6-8	medium	cleaning and finishing, deburring and etching

## 13.0 Blasting Data

**13.1 Table 1 Approximate Air Consumption (CFM) Per Blast Nozzle**

NOZZLE SIZE	NOZZLE PRESSURE						
	60 psi	70 psi	80 psi	90 psi	100 psi	120 psi	140 psi
No.2 1/8"	14	16	18	20	22	26	30
No.3 3/16"	32	36	41	45	49	58	66
No.4 1/4"	57	65	72	80	90	105	121
No.5 5/16"	90	101	113	125	140	160	185
No.6 3/8"	126	145	163	182	200	235	270
No.7 7/16"	170	193	215	240	270	315	360
No.8 1/2"	230	260	290	320	350	410	470
No.10 5/8"	360	406	454	500	550	640	740
No.12 3/4"	518	585	652	720	790	925	1060

**13.2 Table 2 Abrasive Consumption (lbs. per hour) Per Blast Nozzle**

NOZZLE SIZE	NOZZLE PRESSURE						
	60 psi	70 psi	80 psi	90 psi	100 psi	120 psi	140 psi
No.2 1/8"	90	105	115	130	140	165	190
No.3 3/16"	205	230	260	290	320	375	430
No.4 1/4"	365	420	460	500	560	660	760
No.5 5/16"	575	650	725	825	900	1050	1200
No.6 3/8"	840	945	1050	1155	1260	1475	1700
No.7 7/16"	1150	1300	1450	1600	1750	2050	2350
No.8 1/2"	1460	1660	1850	2000	2250	2650	3000
No.10 5/8"	2290	2600	2900	3125	3520	4100	4750
No.12 3/4"	3300	3750	4180	4500	5060	5950	6800

**13.3 Table 3 Hose Selection Guide (blasting @ 100 Psi)**

NOZZLE SIZE	No.4 1/4"	No.5 5/16"	No.6 3/8"	No.7 7/16"	No.8 1/2"
CFM @ 100psi	90	140	200	270	350
AIR HOSE	1 1/4"	1 1/4"	1 1/2"	1 1/2"	2"
BLAST HOSE	1"	1 1/4"	1 1/4"	1 1/2"	1 1/2"
ABRASIVE ( lbs per hr)	560	900	1260	1750	2250

### 13.4 Additional Information on Blasting Productivity

Air volume and pressure are very important. The blasting production rate will increase with higher blasting pressures and decrease with lower blasting pressures. The National Association of Corrosion Engineers' data suggests that for each 1 psi reduction in nozzle pressure, there is a 1.5% production loss. Pressure drop through a Schmidt® blast unit is normally less than 1 psi, while blast units manufactured by some of our competitors have pressure losses as high as 12 psi resulting in an 18% loss of production. Air pressure loss can also be avoided by using the shortest possible hose of adequate size. The inside diameter of both the blast hose (other than whip hose) and the air hose should be approximately three times the diameter of the orifice in the blast nozzle.

Standard Schmidt blast units are rated for a maximum pressure of 125 psi or 150 psi. Refer to the pressure vessel nameplate for maximum operating pressure.



## Technical Specifications and Performance Data

## Spécifications Techniques & Données de Performance

## Technische- und Leistungsdaten

## Specifiche Tecniche e Dati di Esecuzione

## Especificações Técnicas e Dados de Funcionamento

- 1/3 HP Pump Series  
M, MS, MCPV, MDSTV, 29723  
Models
- Pompes Série 1/3 HP  
Modèles M, MS, MCPV, MDSTV,  
29723
- 1/3 PS Pumpenreihe  
M, MS, MCPV, MDSTV, 29723  
Modelle
- Serie Pompe 1/3 HP  
Modelli M, MS, MCPV, MDSTV,  
29723
- Linha de Bombas Hidráulicas de 1/3 HP  
Modelos M, MS, MCPV, MDSTV e 29723



## Introduction

This brochure should be read in conjunction with Catalog MLP-46 and the assembly drawings when supplied as part of the O/M manual with a pump.

## Installation

The Haskel pump can be mounted in any position and be secured by the two mounting brackets. Alternatively, the hydraulic inlet can be directly mounted to the top of a liquid tank. However, models with separation chamber construction (all MD, MCPV and 29723 models) should be mounted vertically so that any fluid leakage from the chamber vent port will not migrate into the air drive section. Pump can be mounted in a horizontal position providing the vent port is facing down. Do not pipe vent port back to fluid source.

## Air Drive System

Other gases such as Nitrogen, CO<sub>2</sub>, Natural Gas – even Sour Gas (H<sub>2</sub>S) can be used as alternatives to compressed air when properly modified. Consult the factory for additional information.

The air drive requires a minimum pressure of 25 psi (1.72 bar) to actuate the air cycling valve spool. However, 40 psi is the recommended minimum for long term reliable operation. The maximum air-drive pressure is 125 psi (8.5 bar). It is not necessary or desirable to use an airline lubricator. The air drive section of all Haskel liquid pumps are pre-lubricated at the time of assembly with Haskel lubrication 50866. The air drive requires no other means of lubrication. Install an air line filter and pressure regulator with a minimum of 1/4" NPT port size. Also review air system upstream and eliminate any restrictions to provide 1/4" minimum inside diameter. Install a shut-off/speed control valve, 1/4" NPT, at pump inlet port.

## Hydraulic System

NOTE: Inlet fluid supply piping should not be less than 1/4" I.D. Restricting the fluid supply will result in lower outlet flow rates and cause pump to cavitate.

Larger internal diameter piping should be used with heavy fluids or if suction head is >3 feet.

**Caution:** Do not loosen liquid inlet or liquid outlet fittings of pump to facilitate make up of connections. These fittings must be tight to avoid leakage or damage. A suction filter must be installed in the liquid inlet line. 100 x 100 mesh is normally ample to protect the pump seals and check valves.

## Priming

Install a valve of suitable working pressure to the pump outlet that is capable of being used as an air bleed to start up. Open air-control valve slowly. Allow pump to cycle for approximately fifteen seconds pumping fluid through the valve. If adequately primed, close the valve. The pump will cycle slowly and then stall due to increase in output resistance. If pump does not stall, open the valve and repeat the procedure.

## Operation

The pump model number indicates the ratio between the area of the air piston and the liquid piston.

The liquid outlet pressure can be controlled quite accurately by regulating the air drive pressure. The pump will cycle rapidly initially and as it approaches an output pressure equal to the ratio times the air drive pressure, it will gradually slow down and finally "stall".

Where it is necessary to obtain maximum outlet flow rates up to a pre-determined pressure, a Haskel Air Pilot Switch should be installed at the pump outlet to automatically stop the pump at the final pressure. The airline regulator should be set at 125 psi (8.6 bar). A Haskel relief valve to prevent over pressurization should also be fitted as a safety precaution.

NOTE: A hand pump attachment can be fitted (for precision control or use without compressed air power) on all models. (Specify with -HP)

## Maintenance

Disconnect pump from system and remove to a clean, well lit work bench with access to vice, tools, seal kits and spares. All parts removed for inspection should be washed in a suitable de-greasing agent such as Blue Gold or equivalent. Inspect all moving parts for wear or scratches. Damaged parts should be replaced. It is recommended that all seals and O-rings are replaced.

Specially packed seal kits are available for Air Drive and Hydraulic Sections. Seal Kit Part Numbers are:

Air Drive P/N 17178 (common to all standard models)

Hydraulic Section	Model No.
P/N 17179 (plus ratio no. e.g., 17179-21)	M-21 thru -188
P/N 26410 (plus ratio no.)	MS-21 thru -188
P/N 28247 (plus ratio no.)	MCPV-21 thru -110
P/N 51104 (plus ratio no.)	29723-21 thru -110
P/N 27901	MDTV-5, MDSTV-5
P/N 53694	M-5
P/N 28696	M-7
P/N 28695	M-12
P/N 51239	MS-7
P/N 51240	MS-12

**Cross Section of Haskel M- and MS- Series Pump**

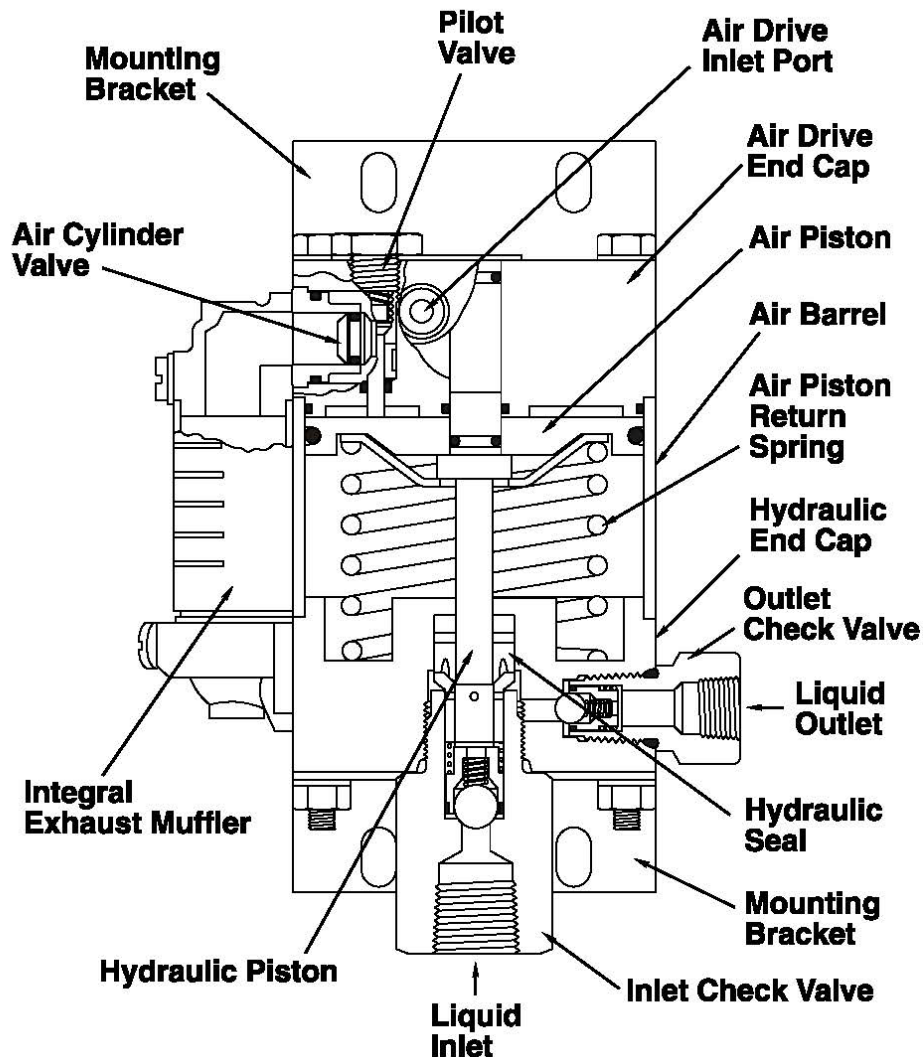

## Air Drive Section

The air piston has a spring return. Care should be taken when dismantling to prevent the spring from causing the top cap to fly off. The most common cause of air drive malfunction is O-ring 568011-21 on the end of spool 17157. Inspect this first and replace if necessary prior to retesting before further disassembly of air drive. Spool 17157 is most easily removed by removing the muffler upper cap and carefully opening the air drive valve to push the spool and sleeve assembly out with compressed air. The spool and sleeve can be contained by holding a cloth over the exhaust port. The air piston, air barrel, cycling valve and sleeve should be re-lubricated on assembly with Haskel Silicone Grease P/N 50866. Torque the tie rod nuts evenly to 50 in-lbs.

## Hydraulic Section

If dismantled for inspection and parts replacement use following torque values on re-assembly:

Assembly	Torque Value
Inlet check valve, ratios -7, -12	to 95 ft-lbs.
Inlet check valve, ratios -21, -36	to 50 ft-lbs.
Inlet check valve, ratios -71, -110, -188	to 125 ft-lbs.
Outlet check valves, all ratios	to 50 ft-lbs, except -220 is 75 ft-lbs.

When ordering spare parts advise pump serial no., model no., spare part no., and description.

## Troubleshooting Guide

### Pump will not cycle, pump bypasses air

- Inadequate air
  - a. See comments on: Air drive systems, page 2 and air drive section, on this page.
- Contaminated air system
  - b. Remove sleeve and cycling spool (under upper cap of muffler). Clean, inspect and lubricate with Haskel Lubricant 28442.

### False cycle, leak from pilot exhaust (top center of cap).

- Leakage of pilot system.
  - c. Install new air section seal kit.

### Pump cycles without pumping or does not stall.

- Check valve(s) not seating or leak in system.
  - d. Inspect check valve(s). First inlet check and then outlet check.

### Pump fluid appears at muffler (or vent port on separation models).

- High pressure seal leakage.
  - e. Install new liquid section seal kit.

## Operating and Maintenance Instructions

### CE Compliance Supplement

#### SAFETY ISSUES

- f. Please refer to the main section of this instruction manual for general handling, assembly and disassembly instructions.
- g. Storage temperatures are 25°F – 130°F (-3.9°C – 53.1°C).
- h. Lockout/tagout is the responsibility of the end user.
- i. If the machine weighs more than 39 lbs (18 kg), use a hoist or get assistance for lifting.
- j. Safety labels on the machines and meanings are as follows:



**General Danger**



**Read Operator's Manual**

- k. In an emergency, turn off the air supply.
- l. Warning: If the pump(s) were not approved to ATEX, it must NOT be used in a potentially explosive atmosphere.
- m. Pressure relief devices must be installed as close as practical to the system.
- n. Before maintenance, liquid section(s) should be purged if hazard liquid was transferred.
- o. The end user must provide pressure indicators at the inlet and final outlet of the pump.
- p. Please refer to the drawings in the main instruction manual for spare parts list and recommended spare parts list.

***Our products are backed by outstanding technical support, and excellent reputation for reliability, and world-wide distribution.***

***Nos produits sont fournis par un support technique externe, une excellente réputation concernant la fiabilité, et la distribution mondiale.***

***Unsere Produkte werden durch herausragende technische Unterstützung, exzellente Verlässlichkeit und globalen Vertrieb unterstützt.***

***I nostri prodotti sono dotati di eccezionali supporti tecnici, eccellente reputazione di affidabilità, e distribuzione globale.***

***Nossos produtos têm o respaldo de uma excelente assistência técnica, uma grande reputação de confiabilidade e um eficiente sistema de distribuição em todo o mundo.***

#### LIMITED WARRANTY

Haskel manufactured products are warranted free of original defects in material and workmanship for a period of one year from the date of shipment to first user. This warranty does not include packings, seals, or failures caused by lack of proper maintenance, incompatible fluids, foreign materials in the driving media, in the pumped media, or application of pressures beyond catalog ratings. Products believed to be originally defective may be returned, freight prepaid, for repair and/or replacement to the distributor, authorized service representative, or to the factory. If upon inspection by the factory or authorized service representative, the problem is found to be originally defective material or workmanship, repair or replacement will be made at no charge for labor or materials, F.O.B. the point of repair or replacement. Permission to return under warranty should be requested before shipment and include the following: The original purchase date, purchase order number, serial number, model number, or other pertinent data to establish warranty claim, and to expedite the return of replacement to the owner.

If unit has been disassembled or reassembled in a facility other than Haskel, warranty is void if it has been improperly reassembled or substitute parts have been used in place of factory manufactured parts.

Any modification to any Haskel product, which you have made or may make in the future, has been and will be at your sole risk and responsibility, and without Haskel's approval or consent. Haskel disclaims any and all liability, obligation or responsibility for the modified product; and for any claims, demands, or causes of action for damage or personal injuries resulting from the modification and/or use of such a modified Haskel product.

HASKEL'S OBLIGATION WITH RESPECT TO ITS PRODUCTS SHALL BE LIMITED TO REPLACEMENT, AND IN NO EVENT SHALL HASKEL BE LIABLE FOR ANY LOSS OR DAMAGE, CONSEQUENTIAL OR SPECIAL, OF WHATEVER KIND OR NATURE, OR ANY OTHER EXPENSE WHICH MAY ARISE IN CONNECTION WITH OR AS A RESULT OF SUCH PRODUCTS OR THE USE OF INCORPORATION THEREOF IN A JOB. THIS WARRANTY IS EXPRESSLY MADE IN LIEU OF ALL OTHER WARRANTIES OR MERCHANTABILITY AND FITNESS FOR A PARTICULAR PURPOSE OR OTHERWISE, OTHER THAN THOSE EXPRESSLY SET FORTH ABOVE, SHALL APPLY TO HASKEL PRODUCTS.

Haskel International Inc.  
100 East Grahm Place  
Burbank, CA 91502 USA

Tel: 818-843-4000  
Email: [sales@haskel.com](mailto:sales@haskel.com)  
[www.haskel.com](http://www.haskel.com)

