



150 KW INDUSTRIAL AIR HEATER

Unit Performance / Data



Hot Dipped Galvanized Skid & Cage

General

Manufacturer Custom Air Products & Services, Inc.
 Unit Model Number PHUH-0NN-150KE0NN-GE5-0-VUP
 Equipment Insurance Value \$43,500.00
 Duct Connections 1 x 20" Supply Air & 1 x 20" Return Air

Dimensions

Length (Base) 96" (8")
 Width 50" (4'2")
 Height w Casters 55 1/4" (4'-7")
 Height w/o Casters 50 5/8" (4'-2")
 Unit Weight 2,500 Lbs.

Electrical

Single Point Power Supply 480V / 3PH / 60HZ
 Connections 4 Cam-Lok connectors

Heating MCA 205
 Heating MOCP 250

CFM	TSP	MOTOR HP
8,000	5.00	10

Heating

For more information contact:
 Custom Air Products & Services (CAPS)
www.customairproducts.com
 (713) 460-9009



150 KW INDUSTRIAL AIR HEATER

Unit Pictures / Drawings



Industrial Heater Control Panel

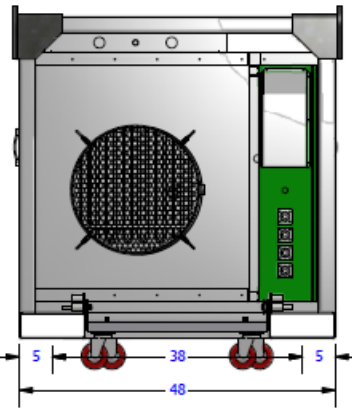

Supply Air View with Dimensional Data



Rear View with Hot Dipped Galvanized Skid & Cage

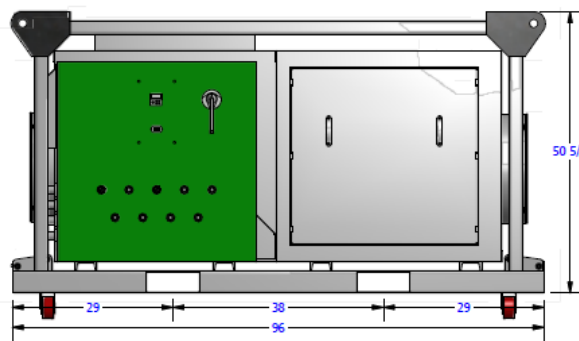

.PS)





One (1) 20" Return Air with Casters & Hot Dipped Galvanized Skid & Cage

Industrial Heater Control Panel
with Dimensional Data
Product Data

ATER

One (1) 20" Supply Air with Casters

150 kW Industrial Air Heater Features:

- Four (4) stages of heating capacity control
- Heater High-Medium-Low capacity selector switch
 - High (all four (4) stages) =150 kW
 - Medium (three (3) stages) =112.50 kW
 - Low (two (2) stages) =75 kW
- 8,000 CFM high static plenum fan rated at 5.00 TSP
- 10 HP, 3600 RPM motor, TEFC
- VFD air volume control
- Direct drive plenum fan
- Unit capable of 300 F leaving air temperature
- Easy access panels for efficient serviceability
- Heavy duty skid, forklift slots, tie-downs. Hot dipped galvanized skid & cage
- 1" Thermax cabinet insulation
- Coated Lifting / Stacking cage
- Rugged design built for rental duty
- Corrosion resistant hardware
- Each unit shall have one (1) supply air collars, sized 20" round and are welded to the exterior wall.
- Each unit shall have one (1) return air collars, sized 20" round and are welded to the exterior wall.
- Integrated duct clamps on each 20" inlet / outlet
- Integrated casters
- **3rd party listed by ETL for both USA and Canada**

150 kW Industrial Air Heater Functions:

- Single point 480V / 3PH / 60HZ power application power connection utilizing four (4) Cam-Lock power cables
- Panel mounted high voltage disconnect
- Main power on indicator light (green)
- Phase monitor and phase fail indicator light (red)
- Master On / Off switch
- Air flow differential pressure safety switch
- Heater safety control circuit and limits
- Micro processor temperature controller
- Entering and leaving air temperature control capability
- Over temperature pilot light
- Four (4) amber pilot light for heat stages energized

For more information contact:

Custom Air Products & Services (CAPS)

www.customairproducts.com

(713) 460-9009



150 KW INDUSTRIAL AIR HEATER

Unit Performance / Data

Operating Performance

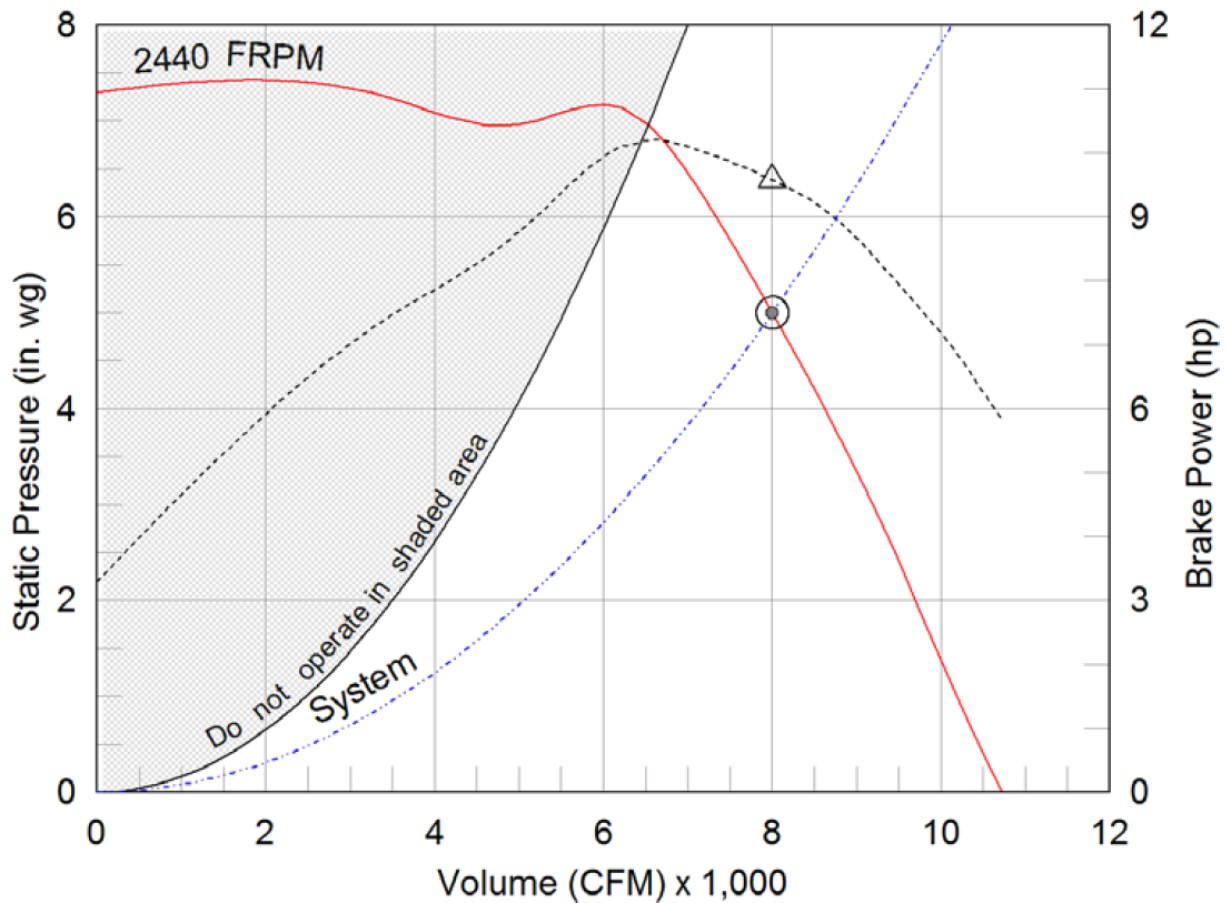

Fan Performance

Motor	10 HP
Motor Type	TEFC
Drive Configuration	Direct
Variable Speed	Yes

For more information contact:
 Custom Air Products & Services (CAPS)
www.customairproducts.com
 (713) 460-9009

Equipment specifications are based manufactures published data; capacity may vary based upon field conditions

**For more information contact:
Custom Air Products & Services (CAPS)
www.customairproducts.com
(713) 460-9009**

Rev 0 - 2017