

HURRICANE 300



Dimensional drawing on other side

SPECIFICATIONS

- **TRAILER MOUNTED/SKID MOUNT - (REMOVABLE FROM TRAILER WITH BUILT-IN FORK POCKETS)**
Chassis - Single, 5,000# axle, rectangular tube frame, two 5-lug radials, DOT-Lighting with electric brakes
- **POWER SOURCE**
Liquid-cooled diesel engine, 4-cylinder 25 HP w/ electric start and locking engine shroud
- **VACUUM AIR FLOW (Blower)**
Positive displacement, 850 CFM, capable of 15" Hg, 3-belt driven
- **FILTRATION SYSTEM (3-Stage)**
Stage 1: Cyclonic separation
Stage 2: Baghouse / 12 Teflon coated, sealed-edge, quick-change filter bags w/ continuous shaker cleaning system
Stage 3: Blower Safety Filter

OPTIONS

- Spare tire carrier
- HEPA filtration
- Skid mounted
- Air compressor
- Blower safety filter
- Electric powered
- Reverse pulse filter cleaning

STANDARD EQUIPMENT

- Paint - one color (custom lettering optional)
- Wet or dry operation
- 13-gallon fuel tank
- Vacuum skid unbolts from trailer, skid has two fork pockets
- 2" ball hitch
- Inspection door (Hopper)
- Vacuum break
- Electric brakes
- Quick release filter access door

SAFETY FEATURES

- OSHA approved belt guard
- Electric brakes
- Optional HEPA filtration
- Emergency breakaway chains
- Blower safety filter
- Engine shroud



INDUSTRIAL VACUUM EQUIPMENT CORPORATION
N8150 Maple Street • Ixonia, WI 53036
800-331-4832 • 920-261-1136 • FAX 920-261-7117
www.IndustrialVacuum.com

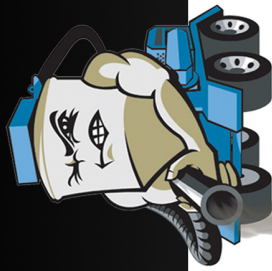

HURRICANE 300



HURRICANE™

DIMENSIONS

WIDTH 80"

WEIGHT 4100 lbs

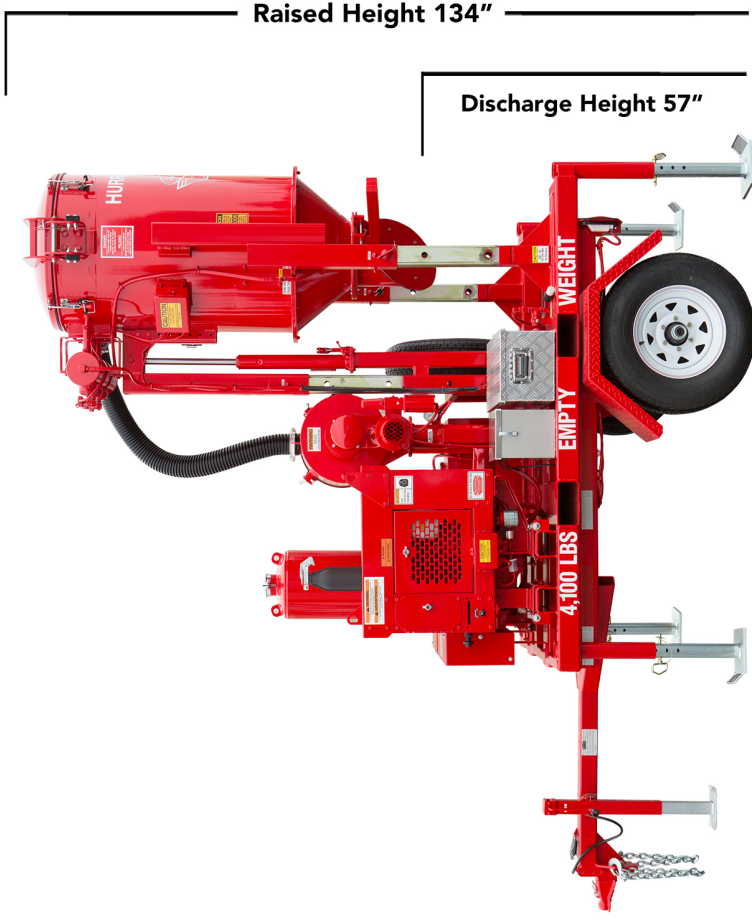
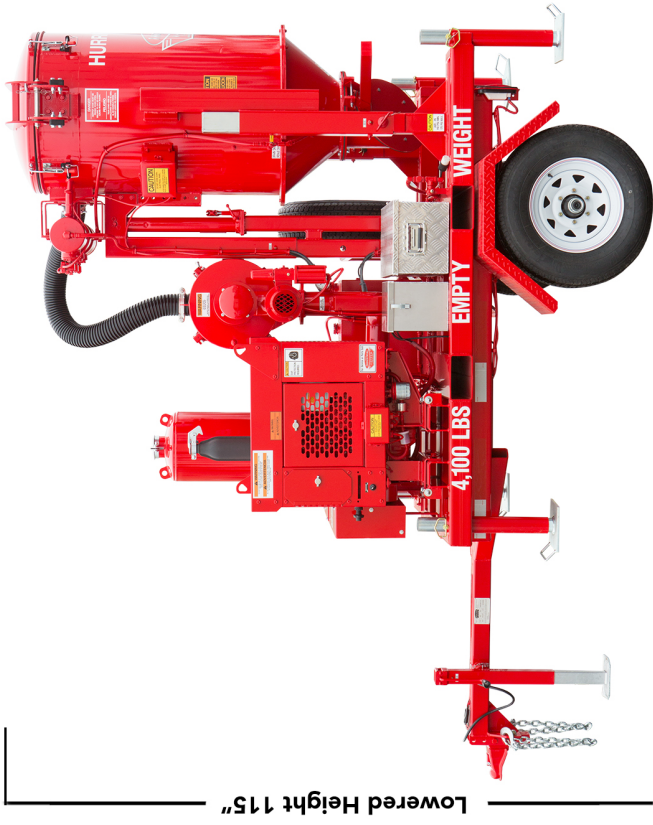

Discharge Height 57"

Length 146"