



Climate by Design International

2100 Park Drive • Owatonna, MN 55060 • 507.451.2198
 Fax: 507.451.1177 • sales@cdihvac.com • www.cdihvac.com

MS-2400/1000 Hi/Lo Mobile-Dry Units

<u>Model</u>	<u>CFM</u>	<u>"A" Dim.</u>	<u>"B" Dim.</u>	<u>"C" Dim.</u>	<u>Weight</u>
CDH-R-126-2.0	2400/1,000*	91 5/8"	35"	63"	1100 lbs

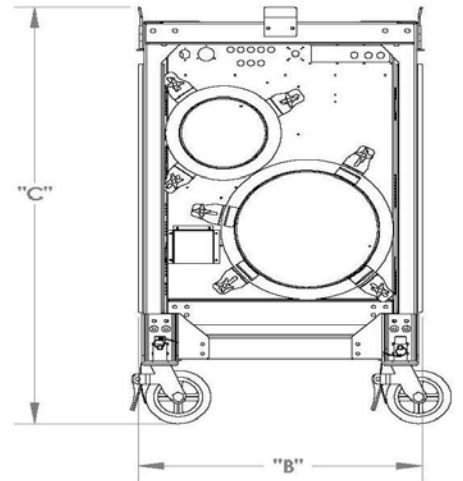
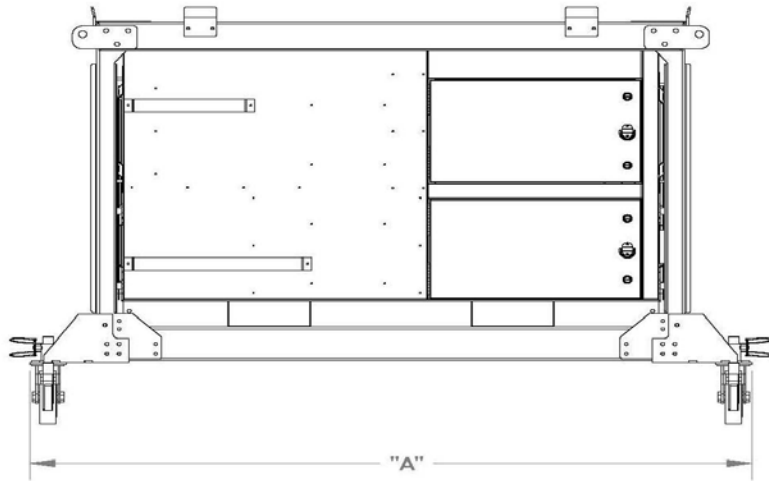

<u>Model</u>	<u>Moisture Removal Lbs/Hr 80°/60% RH</u>	<u>Moisture Removal Gallons/Day 80°/60% RH</u>	<u>Moisture Removal Lbs/Hr 55°/80% RH</u>	<u>Moisture Removal Gallons/Day 55°/80% RH</u>	<u>Moisture Removal Lbs/Hr 40°/80% RH</u>	<u>Moisture Removal Gallons/Day 40°/80% RH</u>	<u>Electric Reactivation FLA Load 460/3/60</u>
CDH-R-126-2.0-Hi	55	158	42	121	25	72	60
CDH-R-126-1.0-Lo	27	79	21	69	12	36	30

Available Accessories:

- (2) Swivel Locking and (2) Fixed Castors
- Lifting and stacking cage
- Remote Humidistat
- Trailer Mounting
- 18" or 20 " Round Supply Connections
- Protective Cage (as shown)



*Weights and Dimensions subject to change without notice

**2" External Static Pressure

Revised 12/23/2020